

P-Channel Enhancement Mode MOSFET

1. Product Information

1.1 Features

- Surface-mounted package
- Extremely low threshold voltage
- Advanced trench cell design

1.2 Applications

- PWM appliances
- Load switch

1.3 Quick reference

- $BV \geq -12\text{ V}$
- $R_{DS(ON)} \leq 28\text{ m}\Omega @ V_{GS} = 2.5\text{ V}$
- $P_{tot} \leq 1.4\text{ W}$
- $R_{DS(ON)} \leq 20\text{ m}\Omega @ V_{GS} = 4.5\text{ V}$
- $I_D \leq -8\text{ A}$

2. Pin Description

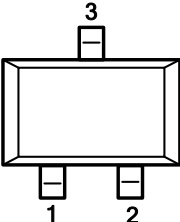
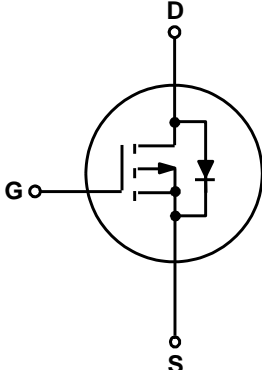
Pin	Description	Simplified Outline	Symbol
1	Gate(G)	 Top View SOT23-3L	
2	Source(S)		
3	Drain(D)		

3. Limiting Values

Symbol	Parameter	Conditions	Min	Max	Unit
V _{DS}	Drain-Source Voltage	T _A = 25 °C	-12	-	V
V _{GS}	Gate-Source Voltage	T _A = 25 °C	-	± 12	V
I _D	Drain Current	T _A = 25 °C, V _{GS} = 4.5 V	-	-8	A
		T _A = 70 °C, V _{GS} = 4.5 V	-	-6	A
I _{DM} ^{*,**}	Pulsed Drain Current	T=330μs	-	-32	A
P _{tot} [*]	Total Power Dissipation	T _A = 25 °C	-	1.4	W
		T _A = 75 °C	-	0.9	
T _{stg}	Storage Temperature		- 55	150	°C
T _J	Junction Temperature		-	150	°C
I _S [*]	Diode Forward Current	T _A = 25 °C	-	-8	A
R _{θJA} [*]	Thermal Resistance- Junction to Ambient		-	125	°C / W

Notes :

- * Surface Mounted on 1 in² pad area, t ≤ 10 sec
- ** Pulse width ≤ 300 μs, duty cycle ≤ 2 %

4. Marking Information

Product Name	Marking
KJ1207A	

5. Ordering Code

Product Name	Package	Reel Size	Tape width	Quantity	Note
KJ1207A	SOT23-3L			3000	

Note: KUAJIEXIN defines “ Green ” as lead-free (RoHS compliant) and halogen free (Br or Cl does not exceed 900 ppm by weight in homogeneous material and total of Br and Cl does not exceed 1500 ppm by weight; Follow IEC 61249-2-21 and IPC / JEDEC J-STD-020C)

6. Electrical Characteristics ($T_A = 25\text{ }^\circ\text{C}$ Unless Otherwise Noted)

Symbol	Parameter	Conditions	Min	Typ	Max	Unit
Static Characteristics						
BV_{DSS}	Drain-Source Breakdown Voltage	$V_{GS} = 0\text{ V}, I_{DS} = 250\text{ }\mu\text{A}$	-12	-18	-	V
$V_{GS(th)}$	Gate Threshold Voltage	$V_{DS} = V_{GS}, I_{DS} = 250\text{ }\mu\text{A}$	-0.45	-0.68	-1.2	V
I_{DSS}	Drain Leakage Current	$V_{DS} = -12\text{ V}, V_{GS} = 0\text{ V}$	-	-	-1	μA
I_{GSS}	Gate Leakage Current	$V_{GS} = \pm 12\text{ V}, V_{DS} = 0\text{ V}$	-	-	± 100	nA
$R_{DS(ON)}^a$	On-State Resistance	$V_{GS} = -4.5\text{ V}, I_{DS} = -8\text{ A}$	-	15	20	m Ω
		$V_{GS} = -2.5\text{ V}, I_{DS} = -8\text{ A}$	-	20	28	
gfs	Forward transconductance	$V_{DS} = -5\text{ V}, I_D = -1\text{ A}$		12		S
Dynamic Characteristics^b						
C_{iss}	Input Capacitance	$V_{GS} = 0\text{ V}, V_{DS} = -10\text{ V}$ Frequency = 1 MHz	-	2700	-	pF
C_{oss}	Output Capacitance		-	680	-	
C_{rss}	Reverse Transfer Capacitance		-	590	-	
$t_d(on)$	Turn-on Delay Time	$V_{DD} = -6\text{ V}, V_{GEN} = -4.5\text{ V},$ $R_G = Q\text{ }\Omega, R_L = 1.2\text{ }\Omega,$ $I_{DS} = -5\text{ A}$	-	11	-	nS
t_r	Turn-on Rise Time		-	35	-	
$t_d(off)$	Turn-off Delay Time		-	30	-	
t_f	Turn-off Fall Time		-	10	-	
Gate Charge Characteristics^b						
Q_g	Total Gate Charge	$V_{DS} = -6\text{ V}, V_{GS} = -4.5\text{ V},$ $I_D = -5\text{ A}$	-	35	-	nC
Q_{gs}	Gate-Source Charge		-	5	-	
Q_{gd}	Gate-Drain Charge		-	10	-	
Drain-Source Diode Characteristics						
V_{SD}	Diode forward voltage	$V_{GS} = -0\text{ V}, I_s = -1\text{ A}$		-0.81	-1.2	V

Notes :

- a : Pulse test ; pulse width $\leq 300\text{ }\mu\text{s}$, duty cycle $\leq 2\%$
- b : Guaranteed by design, not subject to production testing

8. Package Dimensions

SOT23-3L

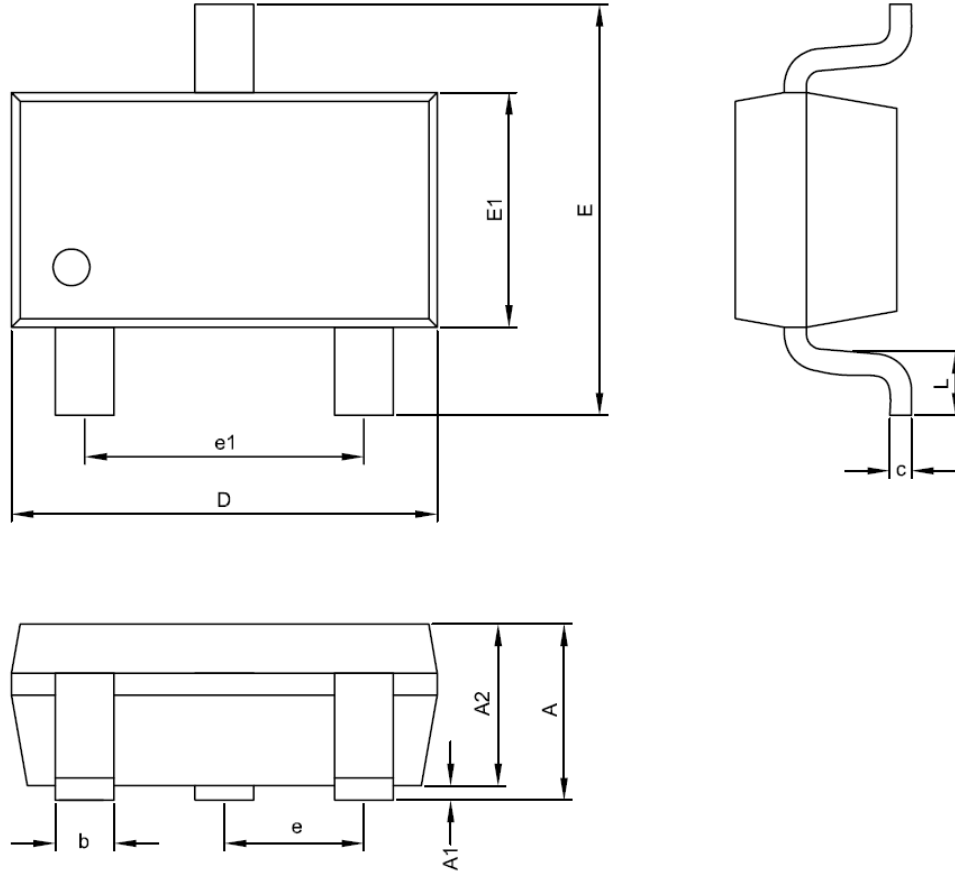

Symbol	Dimensions In Millimeters	
	MIN.	MAX.
A	1.00	1.45
A1	0.00	0.15
A2	1.00	1.30
D	2.70	3.10
E	2.60	3.00
E1	1.50	1.70
c	0.08	0.25
b	0.30	0.50
e	0.95 BSC	
e1	1.90 BSC	
L	0.30	0.60