

P-Channel Enhancement Mode MOSFET

1. Product Information

1.1 Features

- Surface-mounted package
- Advanced trench cell design
- Extremely low threshold voltage

1.2 Applications

- Portable appliances
- Battery management

1.3 Quick reference

- $BV \geq -20\text{ V}$
- $P_{tot} \leq 0.7\text{ W}$
- $I_D \leq -3\text{ A}$
- $R_{DS(ON)} \leq 100\text{ m}\Omega @ V_{GS} = -4.5\text{ V}$
- $R_{DS(ON)} \leq 120\text{ m}\Omega @ V_{GS} = -2.5\text{ V}$

2. Pin Description

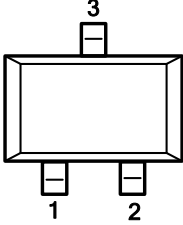
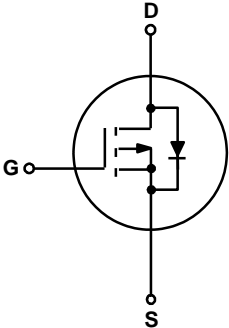
Pin	Description	Simplified Outline	Symbol
1	Gate(G)	 <p>Top View SOT23</p>	
2	Source(S)		
3	Drain(D)		



3. Limiting Values

Symbol	Parameter	Conditions	Min	Max	Unit
V _{DS}	Drain-Source Voltage	T _A = 25 °C	-20	-	V
V _{GS}	Gate-Source Voltage	T _A = 25 °C	-	± 12	V
I _D *	Drain Current	T _A = 25 °C, V _{GS} = 4.5 V	-	-3	A
I _{DM} **	Pulsed Drain Current	T _A = 25 °C, V _{GS} = 4.5 V	-	-10	A
P _{tot} *	Total Power Dissipation	T _A = 25 °C	-	0.7	W
		T _A = 100 °C	-	0.3	
T _{stg}	Storage Temperature		- 55	150	°C
T _J	Junction Temperature		-	150	°C
I _S *	Diode Forward Current	T _A = 25 °C	-	-3	A
R _{θJA} *	Thermal Resistance- Junction to Ambient		-	150	°C / W

Notes :

- * Surface Mounted on 1 in² pad area, t ≤ 10 sec
- ** Pulse width ≤ 300 μs, duty cycle ≤ 2 %

4. Marking Information

Product Name	Marking
KJ2301S	2301

5. Ordering Code

Product Name	Package	Reel Size	Tape width	Quantity	Note
KJ2301S	SOT23			3000	

Note: KUAJIJIXIN defines “ Green ” as lead-free (RoHS compliant) and halogen free (Br or Cl does not exceed 900 ppm by weight in homogeneous material and total of Br and Cl does not exceed 1500 ppm by weight; Follow IEC 61249-2-21 and IPC / JEDEC J-STD-020C)



6. Electrical Characteristics ($T_A = 25\text{ }^\circ\text{C}$ Unless Otherwise Noted)

Symbol	Parameter	Conditions	Min	Typ	Max	Unit
Static Characteristics						
BV_{DSS}	Drain-Source Breakdown Voltage	$V_{GS} = 0\text{ V}, I_{DS} = 250\text{ }\mu\text{A}$	-20	-	-	V
$V_{GS(th)}$	Gate Threshold Voltage	$V_{DS} = V_{GS}, I_{DS} = 250\text{ }\mu\text{A}$	-0.5	-	-1.0	V
I_{DSS}	Drain Leakage Current	$V_{DS} = -20\text{ V}, V_{GS} = 0\text{ V}$	-	-	-1	μA
		$T_J = 85\text{ }^\circ\text{C}$	-	-	-30	μA
I_{GSS}	Gate Leakage Current	$V_{GS} = \pm 12\text{ V}, V_{DS} = 0\text{ V}$	-	-	± 100	nA
$R_{DS(ON)}^a$	On-State Resistance	$V_{GS} = -4.5\text{ V}, I_{DS} = -2\text{ A}$	-	-	100	m Ω
		$V_{GS} = -2.5\text{ V}, I_{DS} = -1.8\text{ A}$	-	-	120	
Diode Characteristics						
V_{SD}^a	Diode Forward Voltage	$I_{SD} = -2\text{ A}, V_{GS} = 0\text{ V}$	-	-	1.2	V
t_{rr}	Reverse Recovery Time	$I_{SD} = -2\text{ A}, dI_{SD}/dt = 100\text{ A}/\mu\text{s}$	-	38	-	nS
Q_{rr}	Reverse Recovery Charge		-	17	-	nC
Dynamic Characteristics^b						
C_{iss}	Input Capacitance	$V_{GS} = 0\text{ V}, V_{DS} = -10\text{ V}$ Frequency = 1 MHz	-	285	-	pF
C_{oss}	Output Capacitance		-	58	-	
C_{rss}	Reverse Transfer Capacitance		-	32	-	
$t_d(on)$	Turn-on Delay Time	$V_{DS} = -10\text{ V}, V_{GEN} = 4.5\text{ V},$ $R_G = 4.5\text{ }\Omega, R_L = 3.3\text{ }\Omega,$ $I_{DS} = -2\text{ A}$	-	9.8	-	nS
t_r	Turn-on Rise Time		-	4.9	-	
$t_d(off)$	Turn-off Delay Time		-	20.5	-	
t_f	Turn-off Fall Time		-	7	-	
Gate Charge Characteristics^b						
Q_g	Total Gate Charge	$V_{DS} = -10\text{ V}, V_{GS} = -4.5\text{ V},$ $I_{DS} = -2\text{ A}$	-	2.9	-	nC
Q_{gs}	Gate-Source Charge		-	0.45	-	
Q_{gd}	Gate-Drain Charge		-	0.75	-	

Notes :

- a : Pulse test ; pulse width $\leq 300\text{ }\mu\text{s}$, duty cycle $\leq 2\%$
- b : Guaranteed by design, not subject to production testing

7. Typical Characteristics

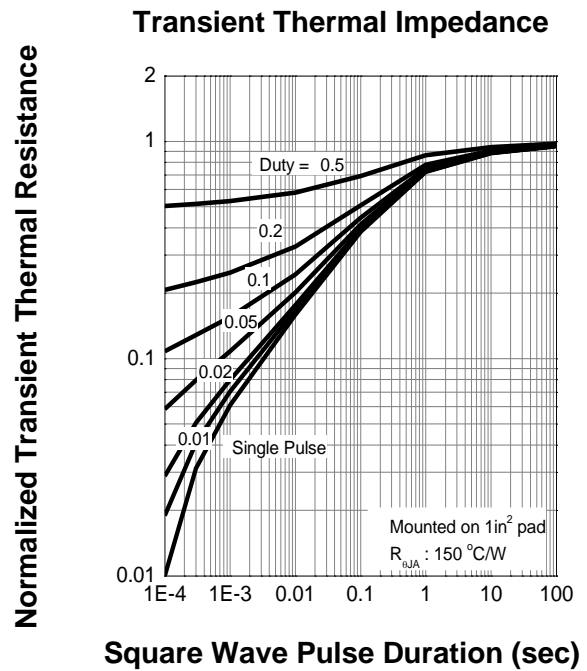
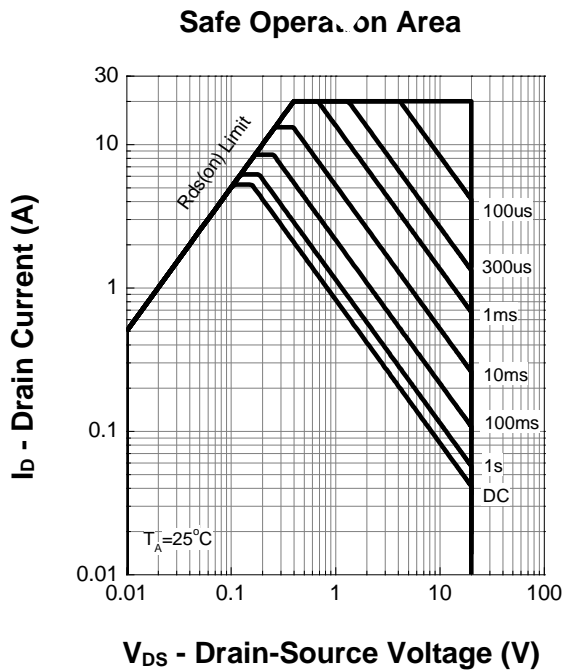
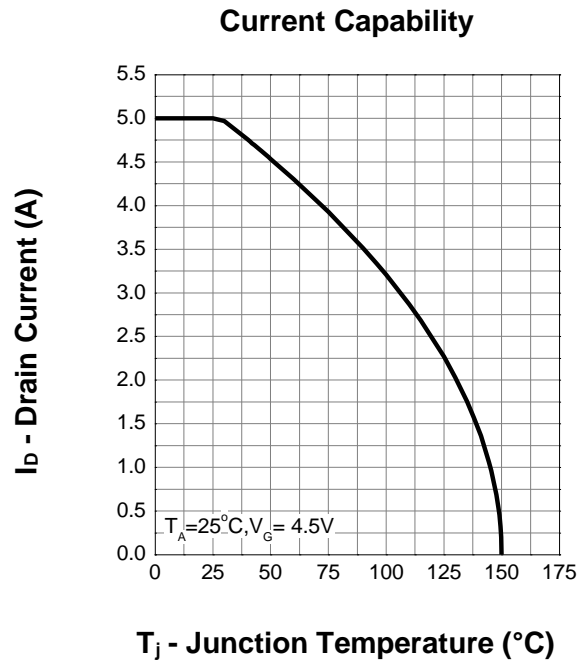
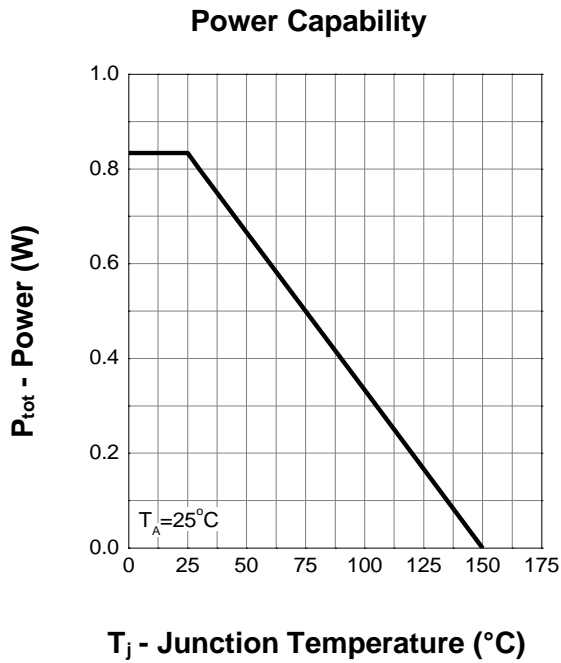



7. Typical Characteristics (cont.)

Output Characteristics

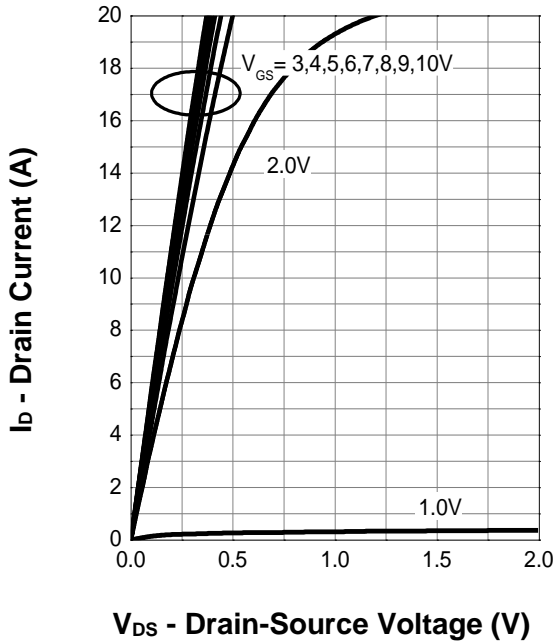

On Resistance

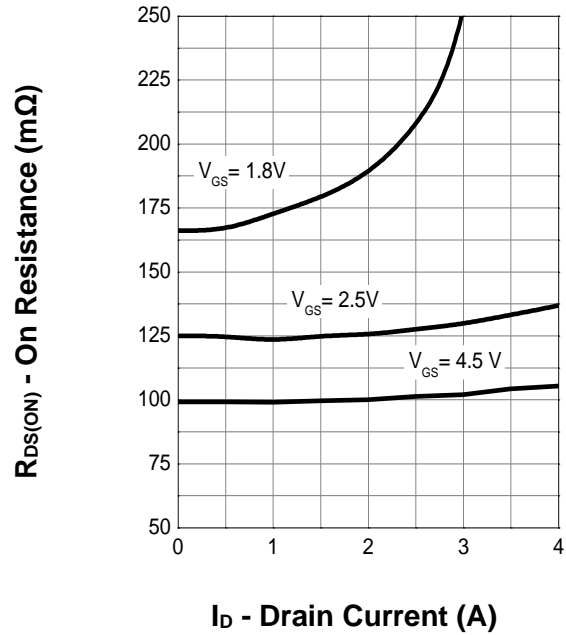

Transfer Characteristics

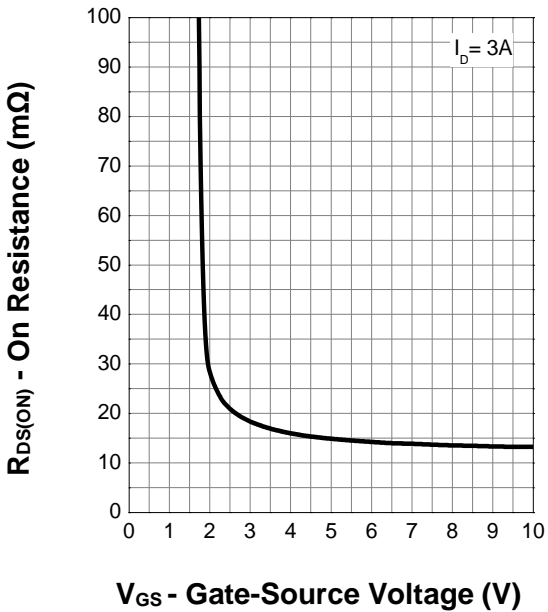

Normalized Threshold Voltage

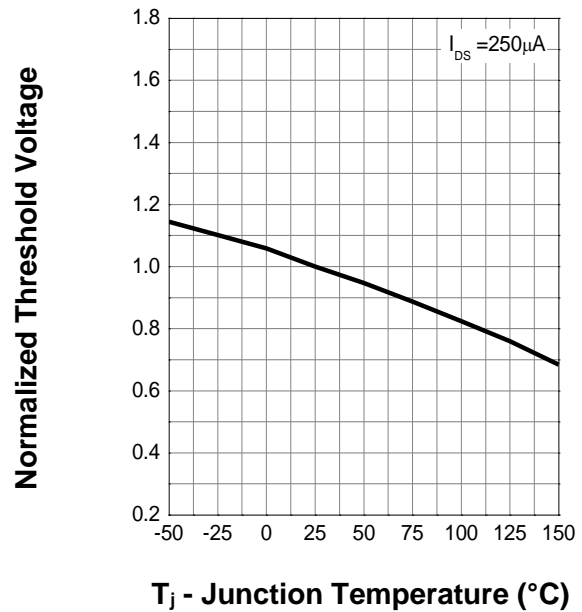



7. Typical Characteristics (cont.)

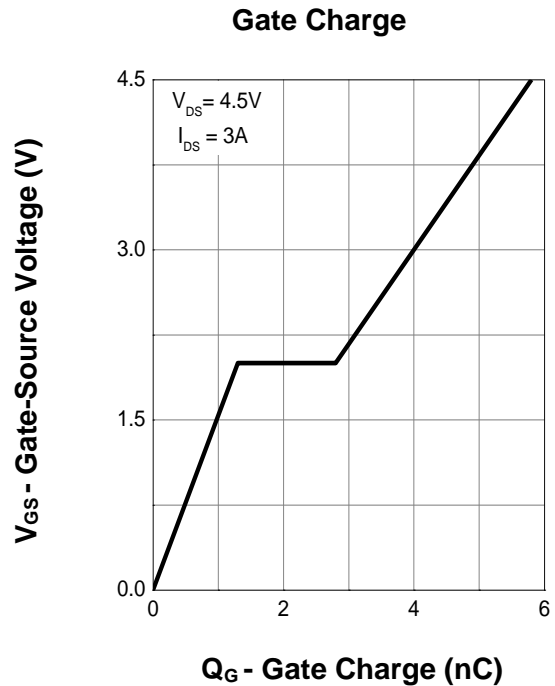
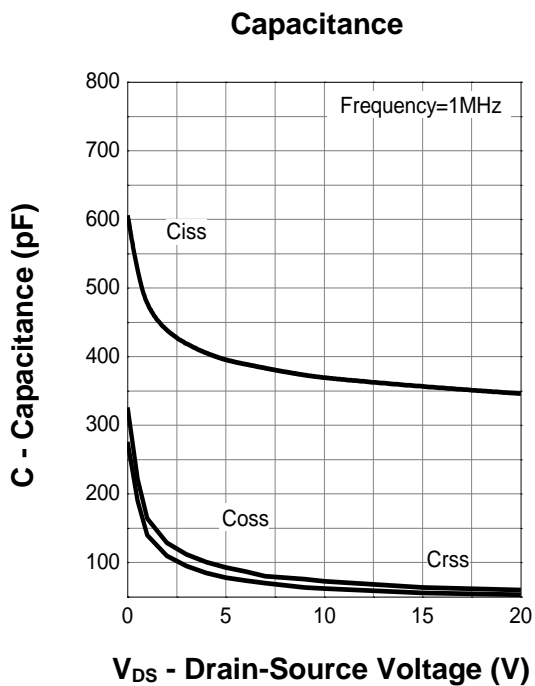
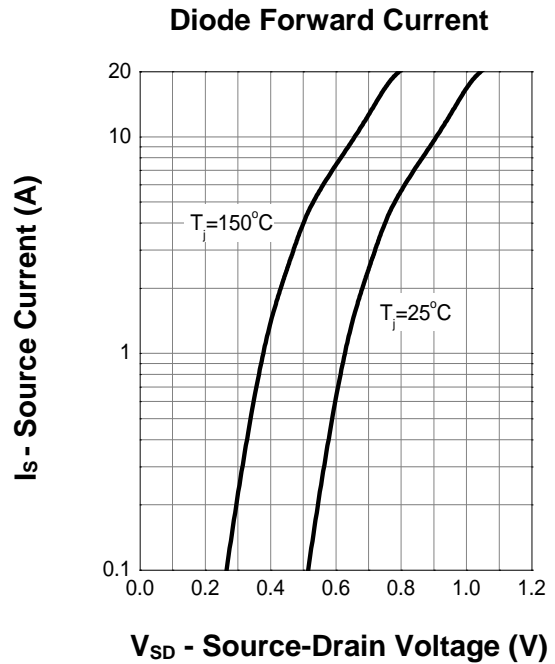
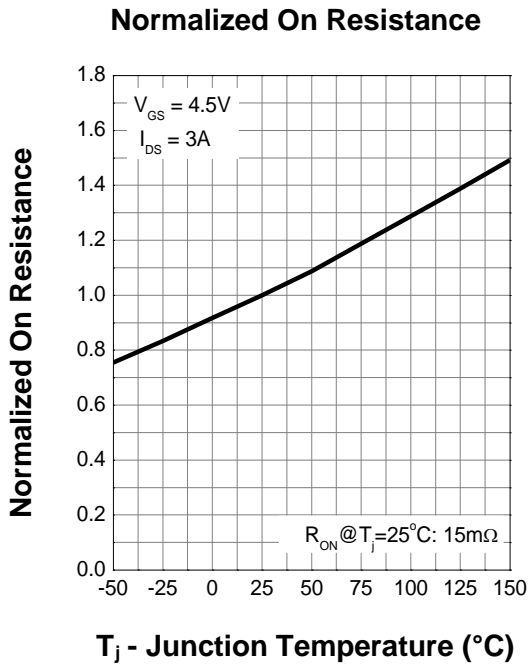



8. Package Dimensions

SOT23

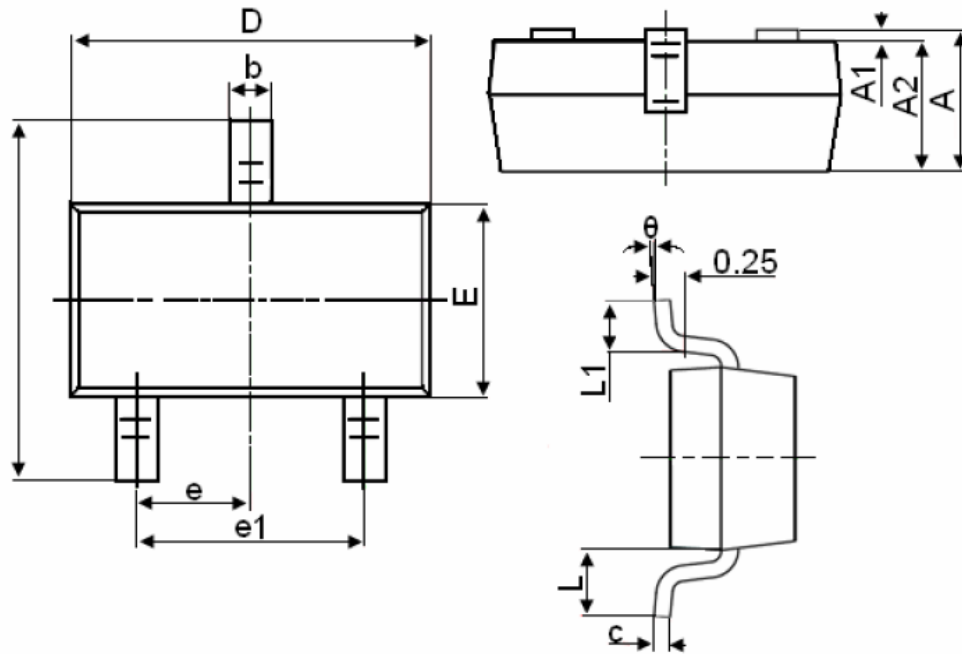

Symbol	Dimensions in Millimeters	
	MIN.	MAX.
A	0.900	1.150
A1	0.000	0.100
A2	0.900	1.050
b	0.300	0.500
c	0.080	0.150
D	2.800	3.000
E	1.200	1.400
E1	2.250	2.550
e	0.950TYP	
e1	1.800	2.000
L	0.550REF	
L1	0.300	0.500
θ	0°	8°