

## P-Channel Enhancement Mode MOSFET

### 1. Product Information

#### 1.1 Features

- Surface-mounted package
- Advanced trench cell design

#### 1.2 Applications

- Portable appliances
- Battery management
- High speed switch
- Low power DC to DC Converter

#### 1.3 Quick reference

- $BV \leq -30\text{ V}$
- $R_{DS(ON)} \leq 50\text{ m}\Omega @ V_{GS} = -10\text{ V}$
- $P_{tot} \leq 1.4\text{ W}$
- $R_{DS(ON)} \leq 60\text{ m}\Omega @ V_{GS} = -4.5\text{ V}$
- $I_D \leq -4.3\text{ A}$
- $R_{DS(ON)} \leq 85\text{ m}\Omega @ V_{GS} = -2.5\text{ V}$

### 2. Pin Description

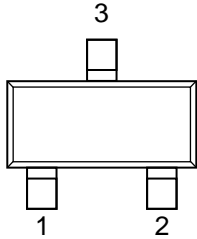
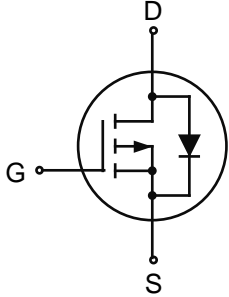
Pin	Description	Simplified Outline	Symbol
1	Gate(G)	 <p>Top View SOT-23</p>	
2	Source(S)		
3	Drain(D)		



### 3. Limiting Values

Symbol	Parameter	Conditions	Min	Max	Unit
$V_{DS}$	Drain-Source Voltage	$T_A = 25\text{ }^\circ\text{C}$	- 30	-	V
$V_{GS}$	Gate-Source Voltage	$T_A = 25\text{ }^\circ\text{C}$	-	$\pm 12$	V
$I_D^*$	Drain Current	$T_A = 25\text{ }^\circ\text{C}, V_{GS} = -10\text{ V}$	-	- 4.3	A
		$T_A = 100\text{ }^\circ\text{C}, V_{GS} = -10\text{ V}$	-	- 2.7	A
$I_{DM}^{*,**}$	Pulsed Drain Current	$T_A = 25\text{ }^\circ\text{C}, V_{GS} = -10\text{ V}$	-	- 17.2	A
$P_{tot}$	Total Power Dissipation	$T_A = 25\text{ }^\circ\text{C}$	-	1.4	W
$T_{stg}$	Storage Temperature		- 55	150	$^\circ\text{C}$
$T_J$	Junction Temperature		-	150	$^\circ\text{C}$
$I_S$	Diode Forward Current	$T_A = 25\text{ }^\circ\text{C}$	-	- 4.3	A
$R_{\theta JA}^*$	Thermal Resistance- Junction to Ambient		-	90	$^\circ\text{C} / \text{W}$

Notes :

- \* Surface Mounted on 1 in<sup>2</sup> pad area,  $t \leq 10\text{ sec}$
- \*\* Pulse width  $\leq 300\text{ }\mu\text{s}$ , duty cycle  $\leq 2\%$

### 4. Marking Information

Product Name	Marking
KJ3401S	<b>3401</b>

### 5. Ordering Code

Product Name	Package	Reel Size	Tape width	Quantity	Note
KJ3401S	SOT-23			3000	

Notes:

KUAIJIEIXIN defines "Green" as lead-free (RoHS compliant) and halogen free (Br or Cl does not exceed 900 ppm by weight in homogeneous material and total of Br and Cl does not exceed 1500 ppm by weight; Follow IEC 61249-2-21 and IPC / JEDEC J-STD-020C)



快捷冠

KJ3401S

## 6. Electrical Characteristics (T<sub>A</sub> = 25 °C Unless Otherwise Noted)

Symbol	Parameter	Conditions	Min	Typ	Max	Unit
<b>Static Characteristics</b>						
BV <sub>DSS</sub>	Drain-Source Breakdown Voltage	V <sub>GS</sub> = 0 V, I <sub>DS</sub> = - 250 μA	- 30	-	-	V
V <sub>GS(th)</sub>	Gate Threshold Voltage	V <sub>DS</sub> = V <sub>GS</sub> , I <sub>DS</sub> = - 250 μA	- 0.7	-	- 1.4	V
I <sub>DSS</sub>	Drain Leakage Current	V <sub>DS</sub> = - 24 V, V <sub>GS</sub> = 0 V	-	-	- 1	μA
		T <sub>J</sub> = 85 °C	-	-	- 30	μA
I <sub>GSS</sub>	Gate Leakage Current	V <sub>GS</sub> = ± 12 V, V <sub>DS</sub> = 0 V	-	-	± 100	nA
R <sub>DS(ON)</sub> <sup>a</sup>	On-State Resistance	V <sub>GS</sub> = - 10 V, I <sub>DS</sub> = - 4 A	-	41	50	m Ω
		V <sub>GS</sub> = - 4.5 V, I <sub>DS</sub> = - 3 A	-	47	60	
		V <sub>GS</sub> = - 2.5 V, I <sub>DS</sub> = - 2 A	-	60	85	
<b>Diode Characteristics</b>						
V <sub>SD</sub> <sup>a</sup>	Diode Forward Voltage	I <sub>SD</sub> = - 4 A, V <sub>GS</sub> = 0 V	-	- 0.8	- 1.3	V
t <sub>rr</sub>	Reverse Recovery Time	I <sub>SD</sub> = - 4 A, dI <sub>SD</sub> /dt = 100 A/μs	-	30	-	ns
Q <sub>rr</sub>	Reverse Recovery Charge		-	2.7	-	nC
<b>Dynamic Characteristics<sup>b</sup></b>						
C <sub>iss</sub>	Input Capacitance	V <sub>GS</sub> = 0 V, V <sub>DS</sub> = -15 V Frequency = 1 MHz	-	750	-	pF
C <sub>oss</sub>	Output Capacitance		-	70	-	
C <sub>rss</sub>	Reverse Transfer Capacitance		-	60	-	
t <sub>d(on)</sub>	Turn-on Delay Time	V <sub>DS</sub> = - 15 V, V <sub>GEN</sub> = - 10 V, R <sub>G</sub> = 6 Ω, R <sub>L</sub> = 3.75 Ω, I <sub>DS</sub> = - 4 A	-	5.8	-	ns
t <sub>r</sub>	Turn-on Rise Time		-	22	-	
t <sub>d(off)</sub>	Turn-off Delay Time		-	172	-	
t <sub>f</sub>	Turn-off Fall Time		-	69	-	
<b>Gate Charge Characteristics<sup>b</sup></b>						
Q <sub>g</sub>	Total Gate Charge	V <sub>GS</sub> = - 10 V, V <sub>DS</sub> = - 15 V, I <sub>DS</sub> = - 4 A	-	17		nC
Q <sub>gs</sub>	Gate-Source Charge		-	2.8		
Q <sub>gd</sub>	Gate-Drain Charge		-	2		

Notes : a : Pulse test ; pulse width ≤ 300 μs, duty cycle ≤ 2 %

b : Guaranteed by design, not subject to production testing

## 7. Typical Characteristics

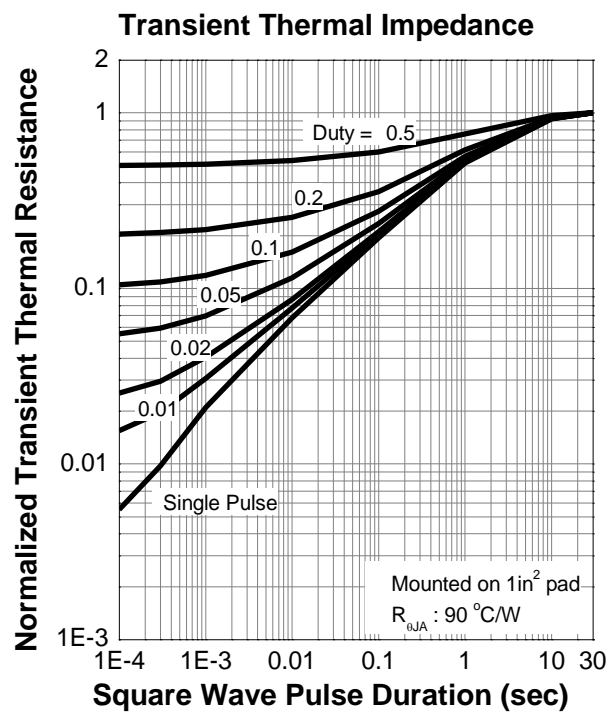
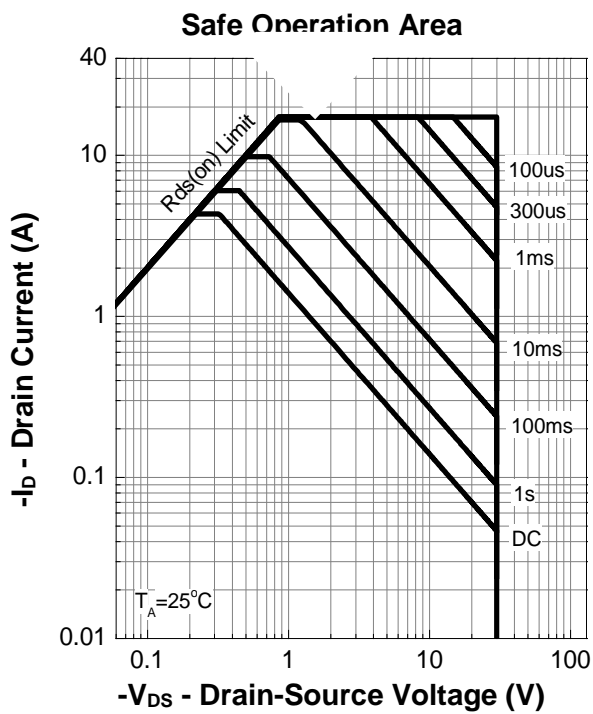
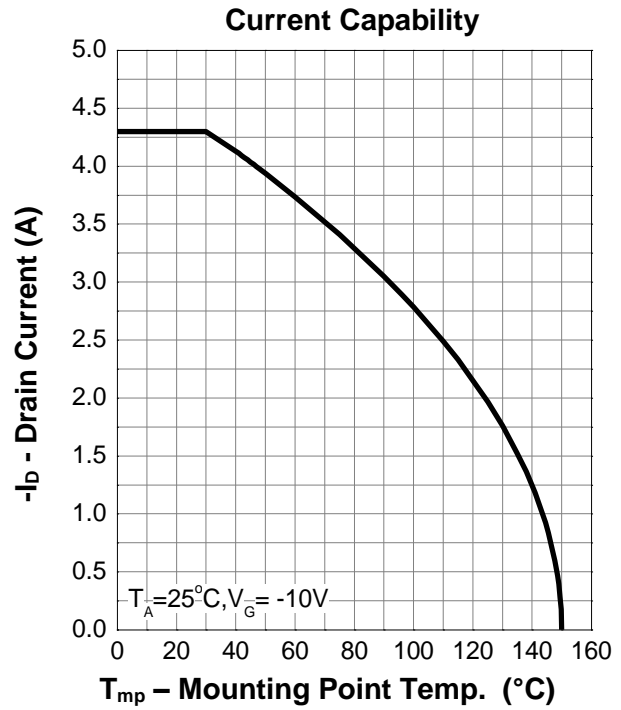
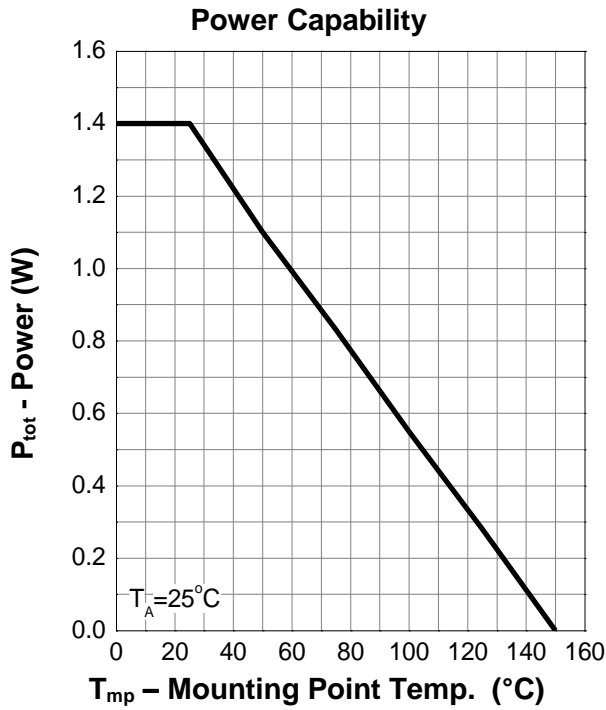



### 7. Typical Characteristics ( cont. )

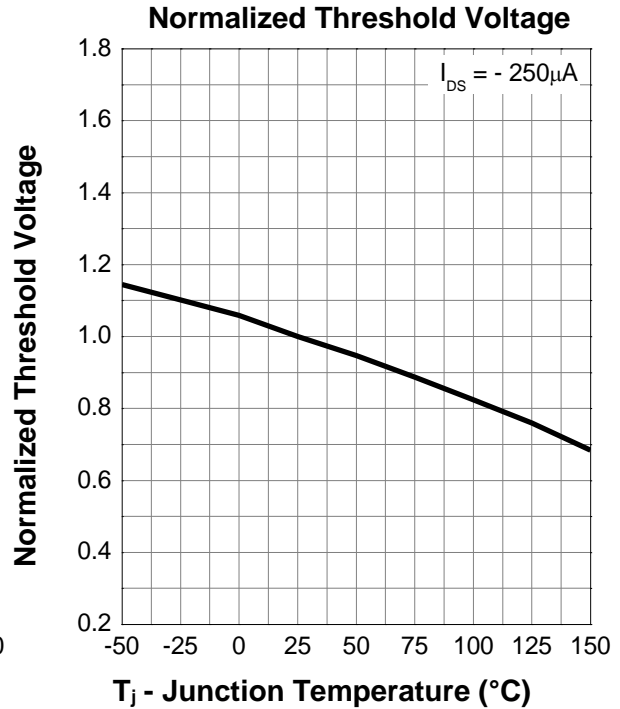
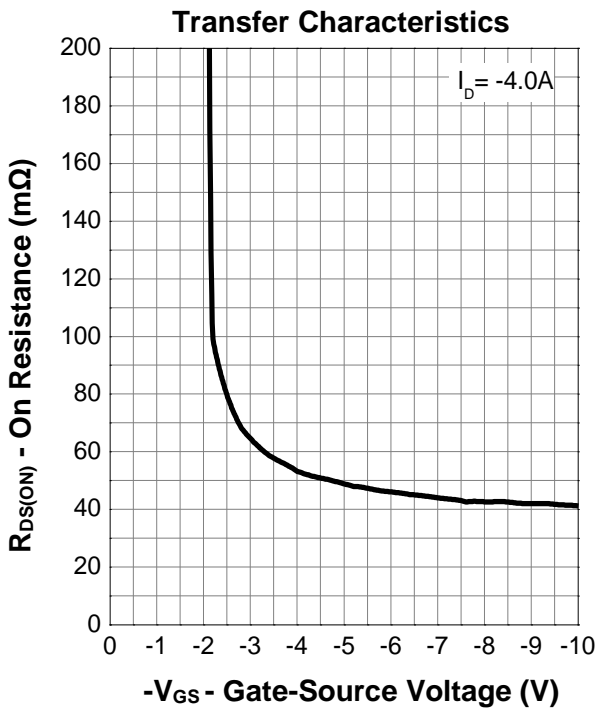
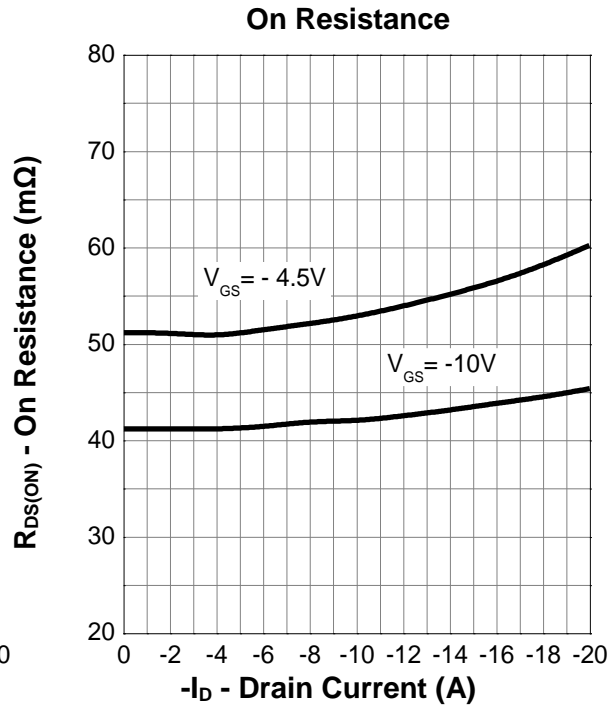
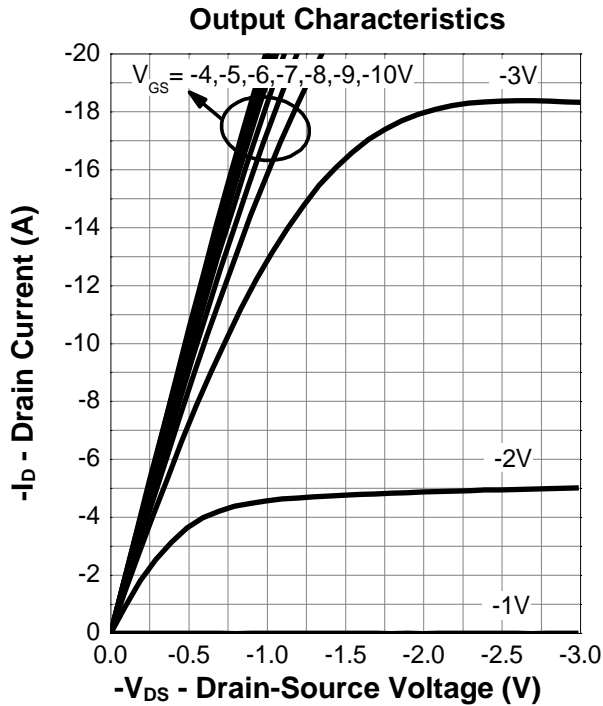



### 7. Typical Characteristics ( cont. )

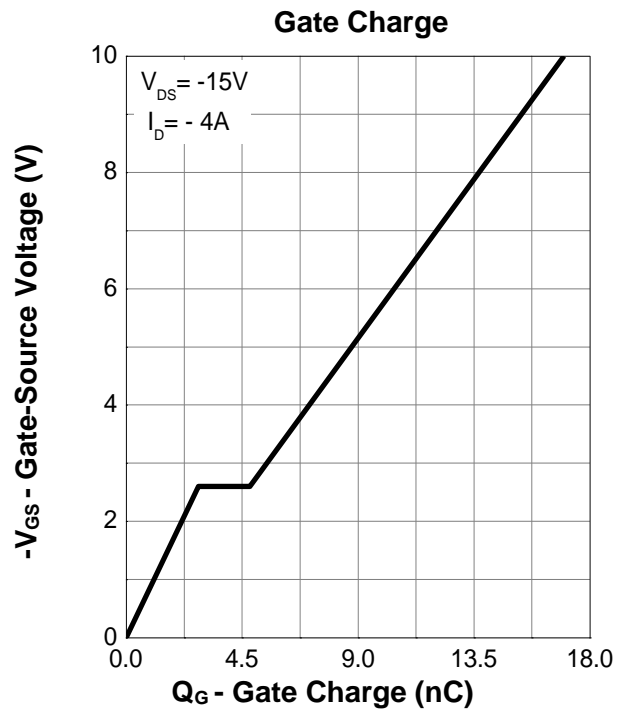
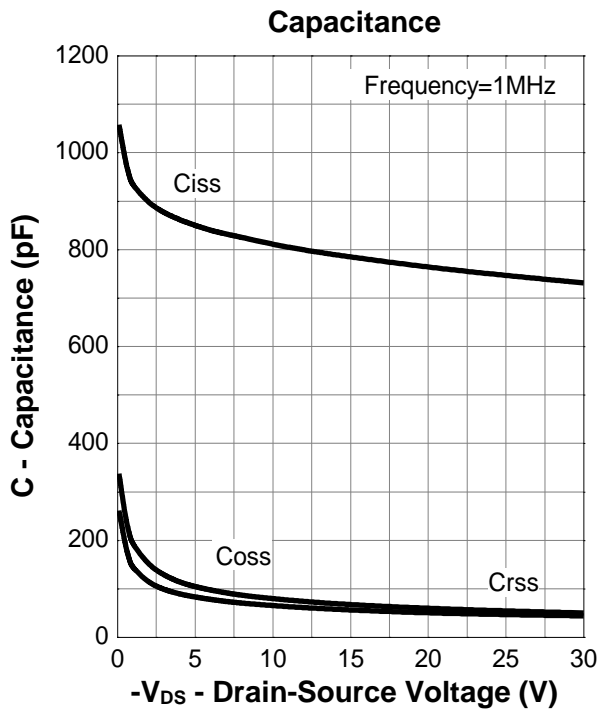
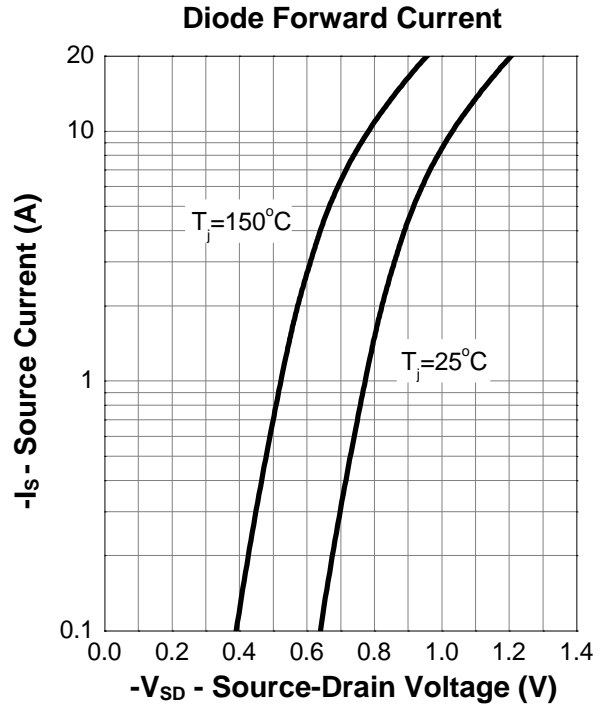
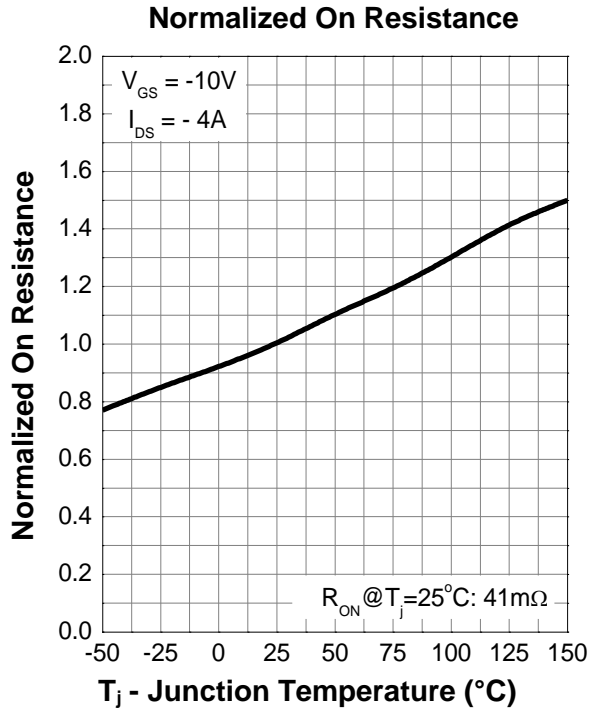



快捷冠

KJ3401S

## 8. Package Dimensions

SOT-23

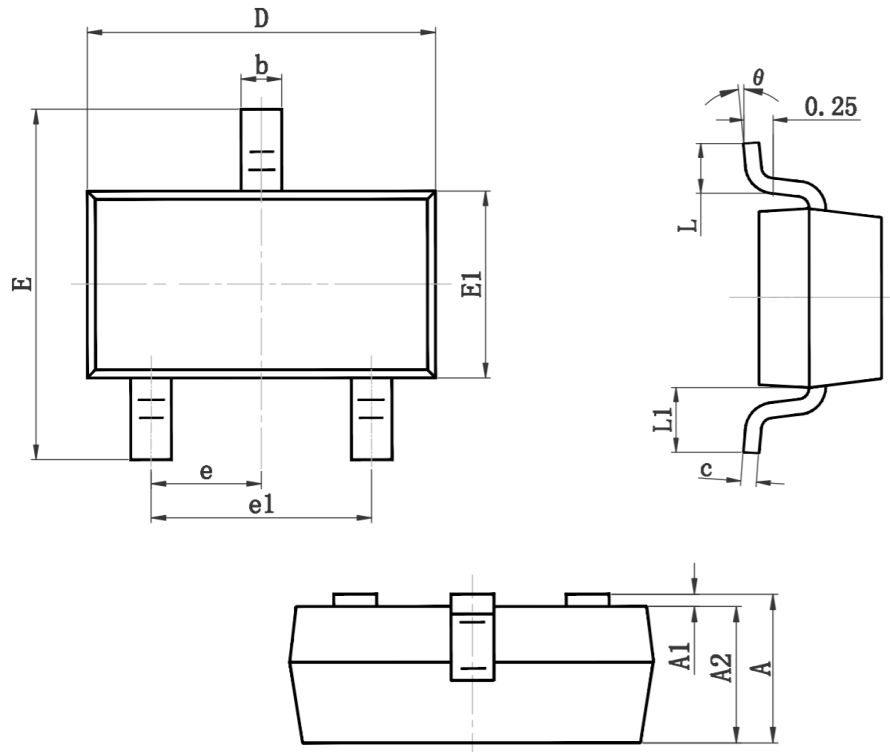

Symbol	Dimensions In Millimeters	
	Min.	Max.
A	0.900	1.150
A1	0.000	0.100
A2	0.900	1.050
b	0.300	0.500
c	0.080	0.150
D	2.800	3.000
E	2.250	2.550
E1	1.200	1.400
e	0.950 TYP.	
e1	1.800	2.000
L	0.300	0.500
L1	0.550 REF.	
$\theta$	0°	8°