

N-Channel Enhancement Mode MOSFET

1. Product Information

1.1 Features

- Surface-mounted package
- Advanced trench cell design
- Extremely low threshold voltage

1.2 Applications

- Portable appliances

1.3 Quick reference

- $BV \geq 20\text{ V}$
- $P_{tot} \leq 1.7\text{ W}$
- $I_D \leq 4.0\text{ A}$
- $R_{DS(ON)} \leq 30\text{ m}\Omega @ V_{GS} = 4.5\text{ V}$
- $R_{DS(ON)} \leq 45\text{ m}\Omega @ V_{GS} = 2.5\text{ V}$

2. Pin Description

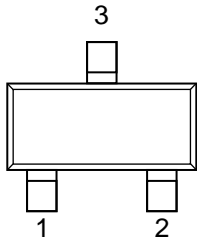
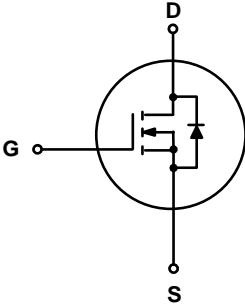
Pin	Description	Simplified Outline	Symbol
1	Gate(G)	 <p>Top View SOT-23</p>	
2	Source(S)		
3	Drain(D)		

3. Limiting Values

Symbol	Parameter	Conditions	Min	Max	Unit
V _{DS}	Drain-Source Voltage	T _A = 25 °C	20	-	V
V _{GS}	Gate-Source Voltage	T _A = 25 °C	-	± 12	V
I _D *	Drain Current	T _A = 25 °C, V _{GS} = 4.5 V	-	4.0	A
I _{DM} **	Pulsed Drain Current	T _A = 25 °C, V _{GS} = 4.5 V	-	12	A
P _{tot} *	Total Power Dissipation	T _A = 25 °C	-	1.7	W
T _{stg}	Storage Temperature		- 55	150	°C
T _J	Junction Temperature		-	150	°C
I _S *	Diode Forward Current	T _A = 25 °C	-	4.0	A
R _{θJA} *	Thermal Resistance- Junction to Ambient		-	145	°C / W

Notes :

* Surface Mounted on 1 in² pad area, t ≤ 10 sec

** Pulse width ≤ 300 μs, duty cycle ≤ 2 %

4. Marking Information

Product Name	Marking
KJ2300S	2300

5. Ordering Code

Product Name	Package	Reel Size	Tape width	Quantity	Note
KJ2300S	SOT-23			3000	

Note: KUAJIEXIN defines " Green " as lead-free (RoHS compliant) and halogen free (Br or Cl does not exceed 900 ppm by weight in homogeneous material and total of Br and Cl does not exceed 1500 ppm by weight; Follow IEC 61249-2-21 and IPC / JEDEC J-STD-020C)

6. Electrical Characteristics ($T_A = 25\text{ }^\circ\text{C}$ Unless Otherwise Noted)

Symbol	Parameter	Conditions	Min	Typ	Max	Unit
Static Characteristics						
BV_{DSS}	Drain-Source Breakdown Voltage	$V_{GS} = 0\text{ V}, I_{DS} = 250\text{ }\mu\text{A}$	20	-	-	V
$V_{GS(th)}$	Gate Threshold Voltage	$V_{DS} = V_{GS}, I_{DS} = 250\text{ }\mu\text{A}$	0.45	0.6	1	V
I_{DSS}	Drain Leakage Current	$V_{DS} = 20\text{ V}, V_{GS} = 0\text{ V}$	-	-	1	μA
		$T_J = 85\text{ }^\circ\text{C}$	-	-	30	μA
I_{GSS}	Gate Leakage Current	$V_{GS} = \pm 12\text{ V}, V_{DS} = 0\text{ V}$	-	-	± 100	nA
$R_{DS(ON)}^a$	Drain-source On-State Resistance	$V_{GS} = 4.5\text{ V}, I_{DS} = 4\text{ A}$	-	26	30	m Ω
		$V_{GS} = 2.5\text{ V}, I_{DS} = 3\text{ A}$	-	37	45	
Gfs	Forward transconductance ^a	$V_{DS} = 10\text{ V}, I_{DS} = 4\text{ A}$		29		S
Diode Characteristics						
V_{SD}^a	Diode Forward Voltage	$I_{SD} = 2.5\text{ A}, V_{GS} = 0\text{ V}$	-	0.76	1.16	V
Dynamic Characteristics^b						
C_{iss}	Input Capacitance	$V_{GS} = 0\text{ V}, V_{DS} = 10\text{ V}$ Frequency = 1 MHz	-	550	-	pF
C_{oss}	Output Capacitance		-	79	-	
C_{rss}	Reverse Transfer Capacitance		-	70	-	
$t_d(on)$	Turn-on Delay Time	$V_{DS} = 10\text{ V}, V_{GEN} = 8\text{ V},$ $R_G = 6\text{ }\Omega, R_L = 2.8\text{ }\Omega,$	-	4	-	nS
t_r	Turn-on Rise Time		-	22	-	
$t_d(off)$	Turn-off Delay Time		-	16	-	
t_f	Turn-off Fall Time		-	9	-	
Q_g	Total Gate Charge	$V_{GS} = 4\text{ V}, V_{DS} = 10\text{ V},$ $I_{DS} = 1\text{ A}$	-	6.4	-	nC
Q_{gs}	Gate-Source Charge		-	0.9	-	
Q_{gd}	Gate-Drain Charge		-	1.4	-	

Notes :

- a : Pulse test ; pulse width $\leq 300\text{ }\mu\text{s}$, duty cycle $\leq 2\%$
- b : Guaranteed by design, not subject to production testing

7. Package Dimensions

SOT-23

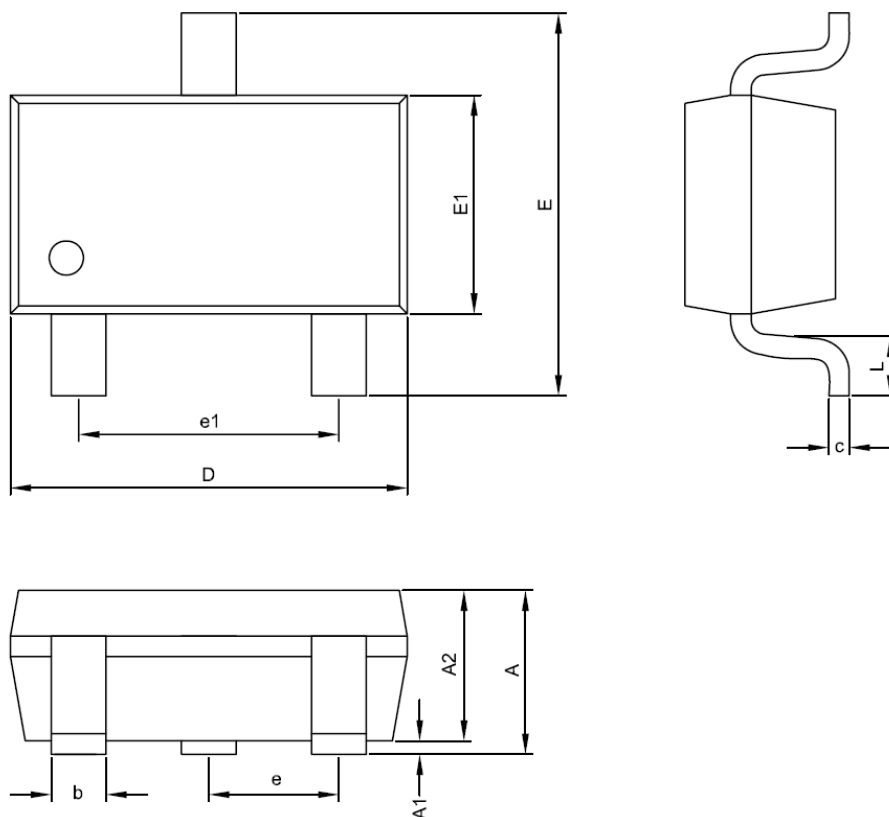

Symbol	Dimensions In Millimeters	
	MIN.	MAX.
A	1.00	1.45
A1	0.00	0.15
A2	1.00	1.30
D	2.70	3.10
E	2.60	3.00
E1	1.50	1.70
c	0.08	0.25
b	0.30	0.50
e	0.95 BSC	
e1	1.90 BSC	
L	0.30	0.60