

N-Channel Enhancement Mode MOSFET

1. Product Information

1.1 Features

- Surface-mounted package
- Advanced trench cell design
- ESD

1.2 Applications

- Portable appliances
- Battery management
- High speed switch
- Low power DC to DC Converter

1.3 Quick reference

- $BV \geq 60\text{ V}$
- $R_{DS(ON)} \leq 85\text{ m}\Omega @ V_{GS} = 10\text{ V}$
- $P_{tot} \leq 1.4\text{ W}$
- $R_{DS(ON)} \leq 96\text{ m}\Omega @ V_{GS} = 4.5\text{ V}$
- $I_D \leq 3.2\text{ A}$

2. Pin Description

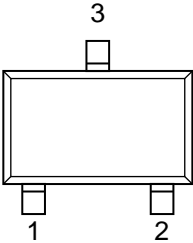
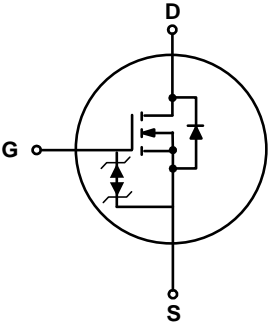
Pin	Description	Simplified Outline	Symbol
1	Gate(G)	 Top View SOT23-3L	
2	Source(S)		
3	Drain(D)		

3. Limiting Values

Symbol	Parameter	Conditions	Min	Max	Unit
V_{DS}	Drain-Source Voltage	$T_A = 25\text{ }^{\circ}\text{C}$	60	-	V
V_{GS}	Gate-Source Voltage	$T_A = 25\text{ }^{\circ}\text{C}$	-	± 20	V
I_D^*	Drain Current (DC)	$T_A = 25\text{ }^{\circ}\text{C}, V_{GS} = 10\text{ V}$	-	3.2	A
		$T_A = 100\text{ }^{\circ}\text{C}, V_{GS} = 10\text{ V}$	-	2	A
I_{DM}^{***}	Drain Current (Pulsed)	$T_A = 25\text{ }^{\circ}\text{C}, V_{GS} = 10\text{ V}$	-	12.8	A
P_{tot}^*	Total Power Dissipation	$T_A = 25\text{ }^{\circ}\text{C}$	-	1.4	W
T_{stg}	Storage Temperature		- 55	150	$^{\circ}\text{C}$
T_J	Junction Temperature		- 55	150	$^{\circ}\text{C}$
I_S	Diode Forward Current	$T_A = 25\text{ }^{\circ}\text{C}$	-	3.2	A
$R_{\theta JA}^*$	Thermal Resistance- Junction to Ambient		-	90	$^{\circ}\text{C} / \text{W}$

Notes :

- * Surface Mounted on 1 in² pad area, $t \leq 10\text{ sec}$
- ** Pulse width $\leq 300\text{ }\mu\text{s}$, duty cycle $\leq 2\%$
- *** Limited by bonding wire

4. Marking Information

Product Name	Marking
KJ6003S	6003

5. Ordering Code

Product Name	Package	Reel Size	Tape width	Quantity	Note
KJ6003S	SOT23-3L			3000	

Note: KUAJIEXIN defines " Green " as lead-free (RoHS compliant) and halogen free (Br or Cl does not exceed 900 ppm by weight in homogeneous material and total of Br and Cl does not exceed 1500 ppm by weight; Follow IEC 61249-2-21 and IPC / JEDEC J-STD-020C)

6. Electrical Characteristics ($T_A = 25\text{ }^\circ\text{C}$ Unless Otherwise Noted)

Symbol	Parameter	Conditions	Min	Typ	Max	Unit
Static Characteristics						
BV_{DSS}	Drain-Source Breakdown Voltage	$V_{GS} = 0\text{ V}, I_{DS} = 250\text{ }\mu\text{A}$	60	-	-	V
$V_{GS(th)}$	Gate Threshold Voltage	$V_{DS} = V_{GS}, I_{DS} = 250\text{ }\mu\text{A}$	1	-	2	V
I_{DSS}	Drain Leakage Current	$V_{DS} = 48\text{ V}, V_{GS} = 0\text{ V}$	-	-	1	μA
I_{GSS}	Gate Leakage Current	$V_{GS} = \pm 20\text{ V}, V_{DS} = 0\text{ V}$	-	-	± 10	μA
$R_{DS(ON)}^a$	On-State Resistance	$V_{GS} = 10\text{ V}, I_{DS} = 2\text{ A}$	-	75	85	m Ω
		$V_{GS} = 4.5\text{ V}, I_{DS} = 1\text{ A}$	-	79	96	
Diode Characteristics						
V_{SD}^a	Diode Forward Voltage	$I_{SD} = 2\text{ A}, V_{GS} = 0\text{ V}$	-	-	1.3	V
t_{rr}	Reverse Recovery Time	$I_{SD} = 2\text{ A}, dI_{SD}/dt = 100\text{ A}/\mu\text{s}$	-	8.2	-	nS
Q_{rr}	Reverse Recovery Charge		-	3.9	-	nC
Dynamic Characteristics^b						
C_{iss}	Input Capacitance	$V_{GS} = 0\text{ V}, V_{DS} = 30\text{ V}$ Frequency = 1 MHz	-	321	-	pF
C_{oss}	Output Capacitance		-	23	-	
C_{rss}	Reverse Transfer Capacitance		-	22	-	
$t_d(on)$	Turn-on Delay Time	$V_{DS} = 30\text{ V}, V_{GEN} = 10\text{ V},$ $R_G = 3.9\text{ }\Omega, R_L = 15\text{ }\Omega,$ $I_{DS} = 2\text{ A}$	-	3.4	-	nS
t_r	Turn-on Rise Time		-	2.8	-	
$t_d(off)$	Turn-off Delay Time		-	14	-	
t_f	Turn-off Fall Time		-	8	-	
Gate Charge Characteristics^b						
Q_g	Total Gate Charge	$V_{GS} = 10\text{ V}, V_{DS} = 30\text{ V},$ $I_{DS} = 2\text{ A}$	-	7.3	-	nC
Q_{gs}	Gate-Source Charge		-	1.4	-	
Q_{gd}	Gate-Drain Charge		-	1.1	-	

Notes : a : Pulse test ; pulse width $\leq 300\text{ }\mu\text{s}$, duty cycle $\leq 2\%$

b : Guaranteed by design, not subject to production testing

7. Typical Characteristics

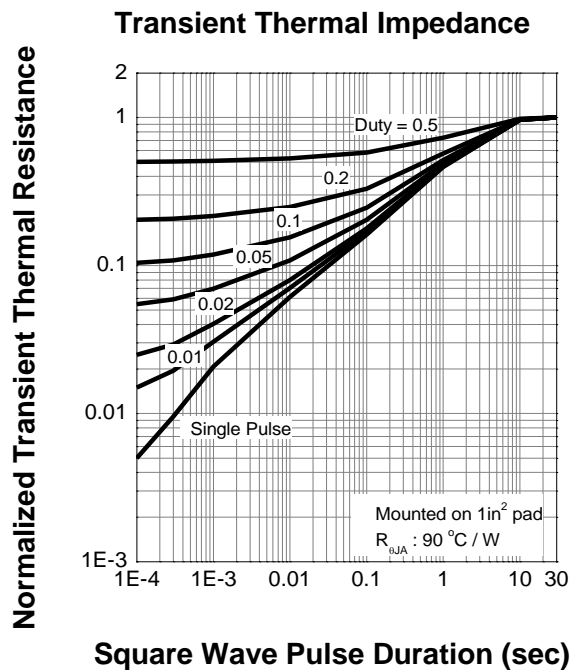
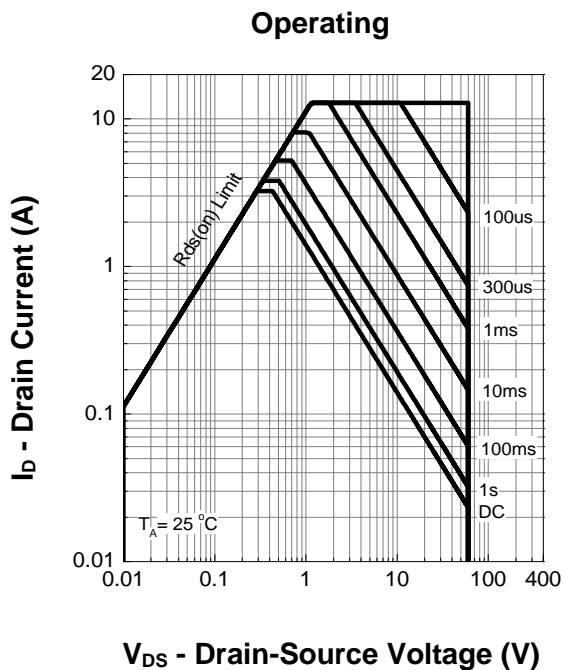
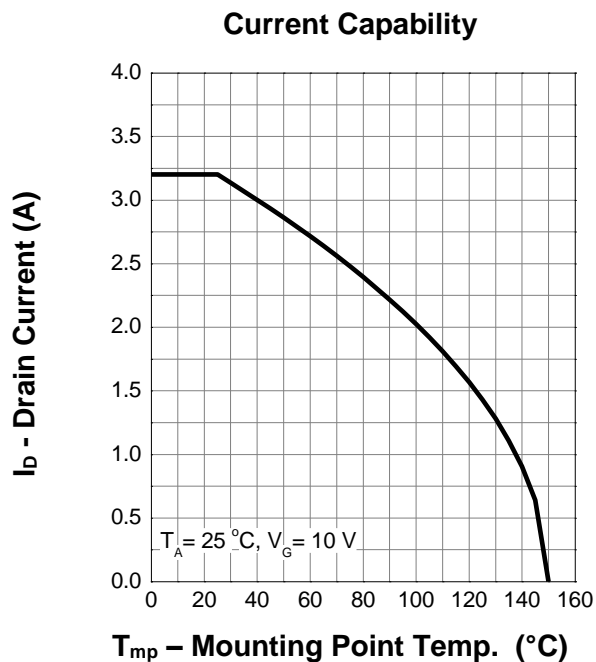
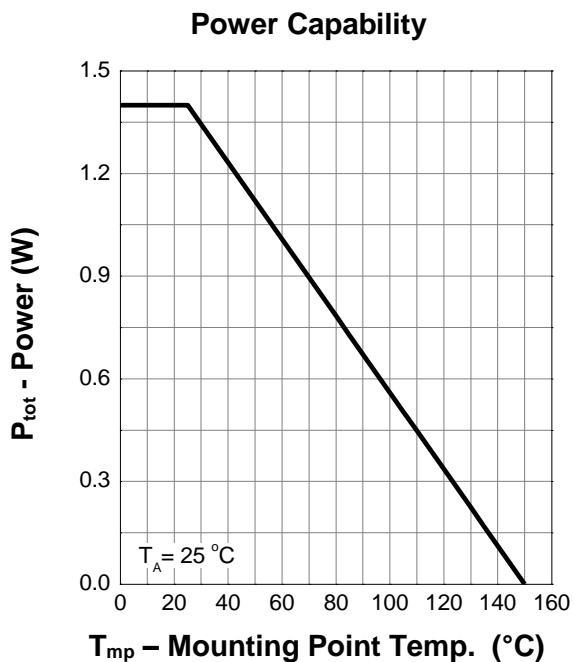

7. Typical Characteristics (cont.)

Output Characteristics

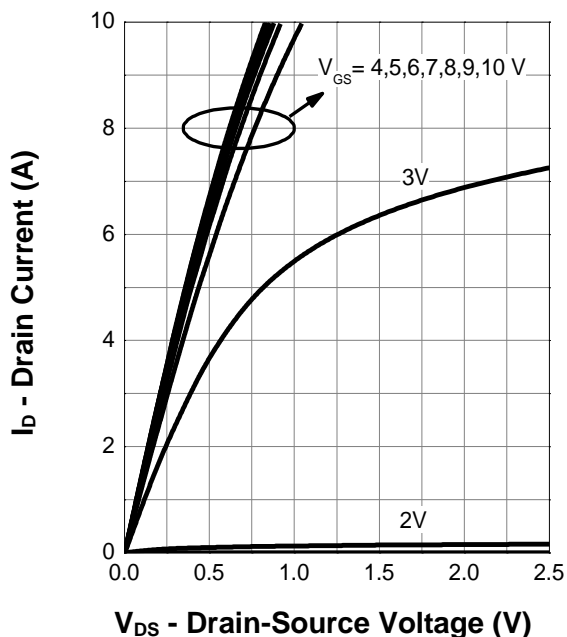

On Resistance

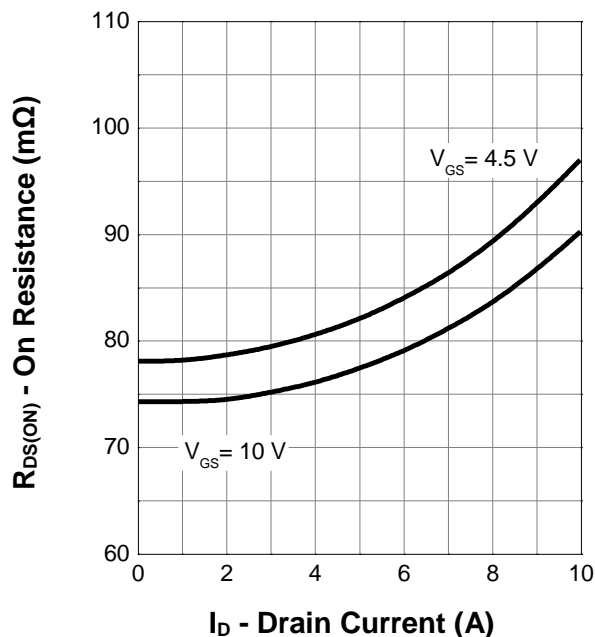

Transfer Characteristics

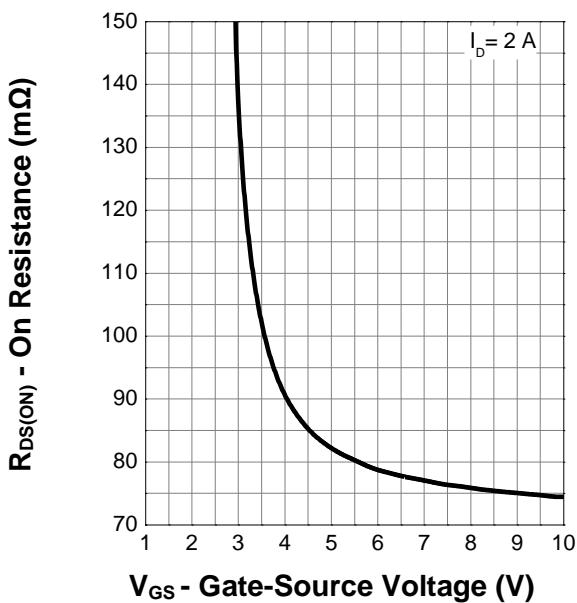

Normalized Threshold Voltage

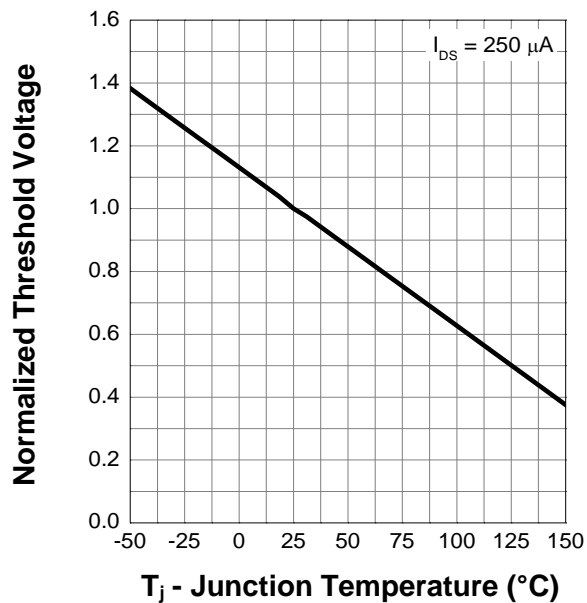

7. Typical Characteristics (cont.)

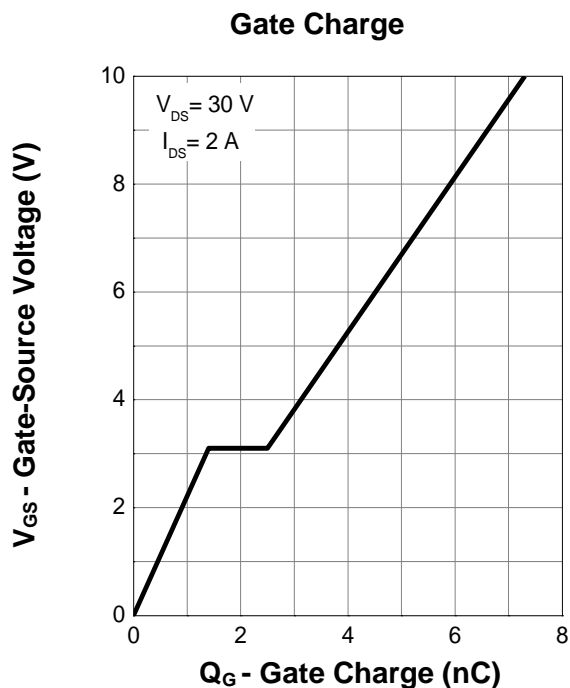
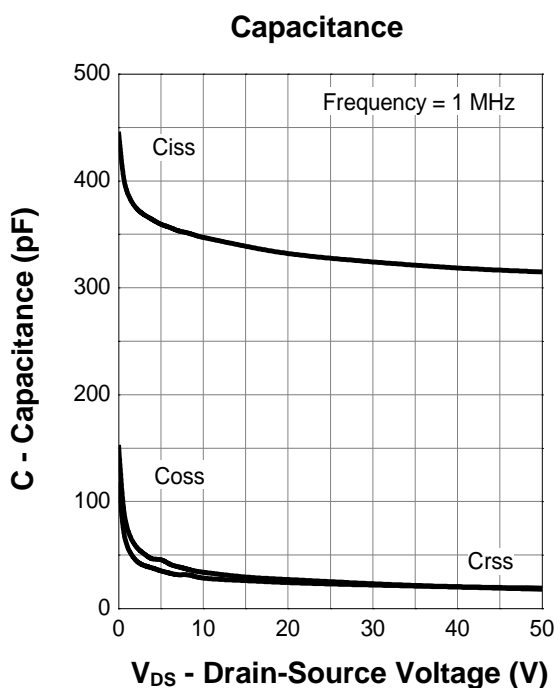
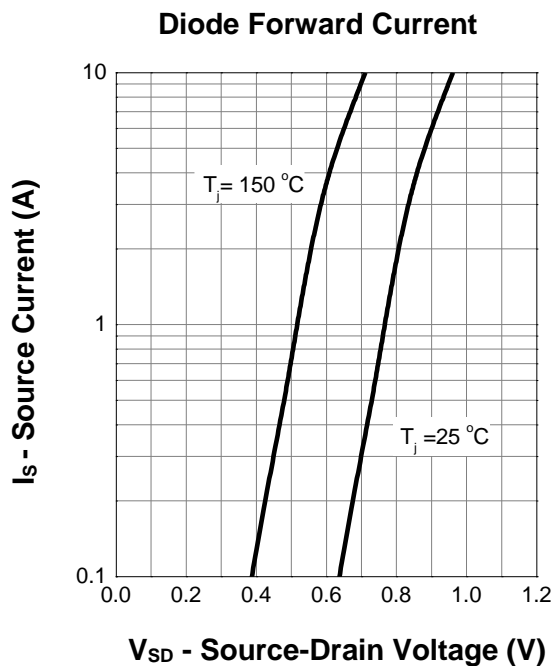
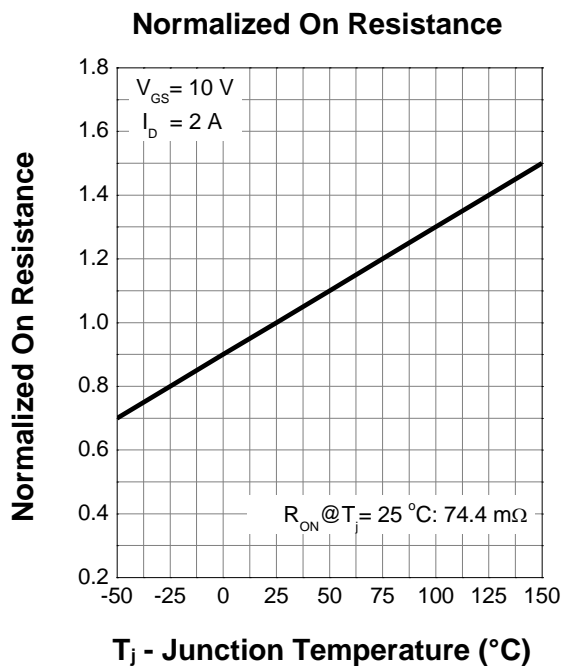

8. Package Dimensions

SOT23-3L

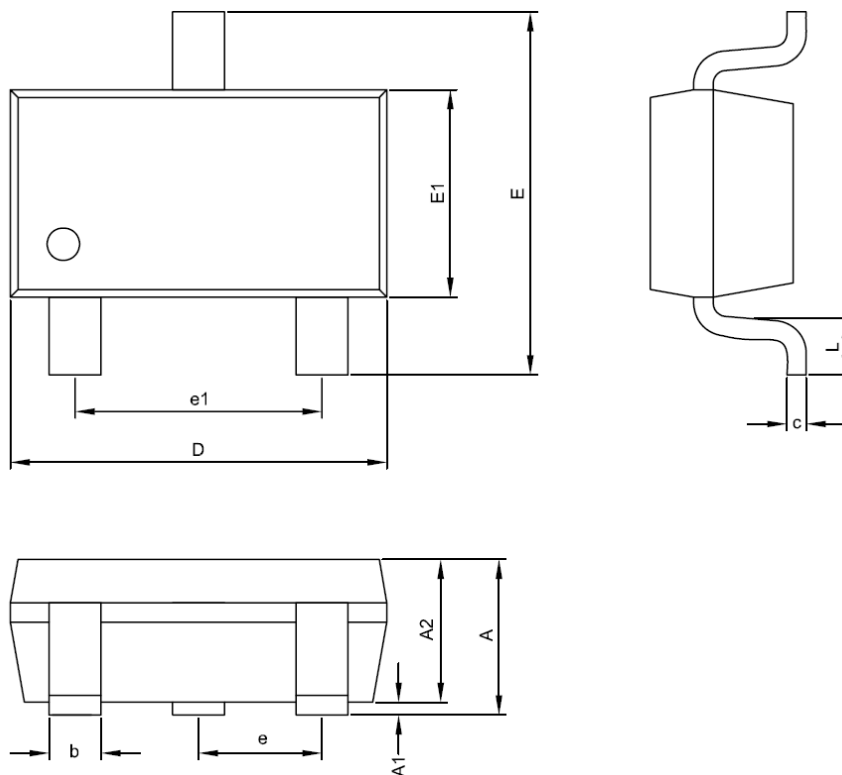

Symbol	Dimensions In Millimeters	
	MIN.	MAX.
A	1.00	1.45
A1	0.00	0.15
A2	1.00	1.30
D	2.70	3.10
E	2.60	3.00
E1	1.50	1.70
c	0.08	0.25
b	0.30	0.50
e	0.95 BSC	
e1	1.90 BSC	
L	0.30	0.60