

N-Channel Enhancement Mode MOSFET

1. Product Information

1.1 Features

- Surface-mounted package
- Extremely low threshold voltage
- Advanced trench cell design
- ESD protected

1.2 Applications

- Portable appliances

1.3 Quick reference

- $BV \geq 60\text{ V}$
- $P_{tot} \leq 0.83\text{ W}$
- $I_D \leq 0.5\text{ A}$
- $R_{DS(ON)} \leq 2.0\ \Omega @ V_{GS} = 10\text{ V}$
- $R_{DS(ON)} \leq 2.7\ \Omega @ V_{GS} = 4.5\text{ V}$

2. Pin Description

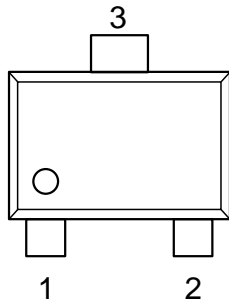
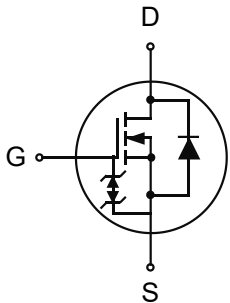
Pin	Description	Simplified Outline	Symbol
1	Gate (G)	 <p style="text-align: center;">Top View SOT-723</p>	
2	Source (S)		
3	Drain (D)		

3. Limiting Values

Symbol	Parameter	Conditions	Min	Max	Unit
V_{DS}	Drain-Source Voltage	$T_A = 25\text{ }^\circ\text{C}$	60	-	V
V_{GS}	Gate-Source Voltage	$T_A = 25\text{ }^\circ\text{C}$	-	± 20	V
I_D^*	Drain Current	$T_A = 25\text{ }^\circ\text{C}, V_{GS} = 10\text{ V}$	-	0.5	A
$I_{DM}^{*,**}$	Pulsed Drain Current	$T_A = 25\text{ }^\circ\text{C}, V_{GS} = 10\text{ V}$	-	2	A
P_{tot}^*	Total Power Dissipation	$T_A = 25\text{ }^\circ\text{C}$	-	0.83	W
T_{stg}	Storage Temperature		- 55	150	$^\circ\text{C}$
T_J	Junction Temperature		-	150	$^\circ\text{C}$
I_S^*	Diode Forward Current	$T_A = 25\text{ }^\circ\text{C}$	-	0.5	A
$R_{\theta JA}^*$	Thermal Resistance- Junction to Ambient		-	150	$^\circ\text{C/W}$

Notes :

- * Surface Mounted on 1 in² pad area, $t \leq 10\text{ sec}$
- ** Pulse width $\leq 300\text{ }\mu\text{s}$, duty cycle $\leq 2\%$
- *** Limited by bonding wire

4. Marking Information

Product Name	Marking
KJ2N7002K	702

5. Ordering Code

Product Name	Package	Reel Size	Tape width	Quantity	Note
KJ2N7002K	SOT-723			3000	

Note: KUIJIEXIN defines " Green " as lead-free (RoHS compliant) and halogen free (Br or Cl does not exceed 900 ppm by weight in homogeneous material and total of Br and Cl does not exceed 1500 ppm by weight; Follow IEC 61249-2-21 and IPC / JEDEC J-STD-020C)

6. Electrical Characteristics (T_A = 25°C Unless Otherwise Noted)

Symbol	Parameter	Conditions	Min	Typ	Max	Unit
Static Characteristics						
BV _{DSS}	Drain-Source Breakdown Voltage	V _{GS} = 0 V, I _{DS} = 250 μA	60	-	-	V
V _{GS(th)}	Gate Threshold Voltage	V _{DS} = V _{GS} , I _{DS} = 250 μA	1	1.5	2	V
I _{DSS}	Drain Leakage Current	V _{DS} = 48 V, V _{GS} = 0 V	-	-	1	μA
I _{GSS}	Gate Leakage Current	V _{GS} = ± 20 V, V _{DS} = 0 V	-	±0.8	-	μA
R _{DS(ON)} ^a	On-State Resistance	V _{GS} = 10 V, I _{DS} = 0.5 A	-	1.5	2	Ω
		V _{GS} = 4.5 V, I _{DS} = 0.2 A	-	2.0	2.7	
Diode Characteristics						
V _{SD} ^a	Diode Forward Voltage	I _{SD} = 0.5 A, V _{GS} = 0 V	-	0.85	-	V
t _{rr}	Reverse Recovery Time	I _{SD} = 0.5 A, dI _{SD} / dt = 100 A / μs	-	30	-	ns
Q _{rr}	Reverse Recovery Charge		-	29	-	nC
Dynamic Characteristics^b						
R _G	Gate Resistance	V _{GS} = V _{DS} = 0 V, F = 1 MHz	-	200	-	Ω
C _{iss}	Input Capacitance	V _{GS} = 0 V, V _{DS} = 25 V Frequency = 1 MHz	-	14.7	-	pF
C _{oss}	Output Capacitance		-	0.76	-	
C _{rss}	Reverse Transfer Capacitance		-	0.63	-	
t _{d(on)}	Turn-on Delay Time	V _{DS} = 30 V, V _{GEN} = 10 V, R _G = 25 Ω, R _L = 60 Ω, I _{DS} = 0.5 A	-	2.7	-	ns
t _r	Turn-on Rise Time		-	2.5	-	
t _{d(off)}	Turn-off Delay Time		-	13	-	
t _f	Turn-off Fall Time		-	8	-	
Q _g	Total Gate Charge	V _{GS} = 4.5 V, V _{DS} = 10 V, I _{DS} = 0.5 A	-	0.44	-	nC
Q _{gs}	Gate-Source Charge		-	0.2	-	
Q _{gd}	Gate-Drain Charge		-	0.1	-	

Notes :

a: Pulse test ; pulse width ≤ 300 μs, duty cycle ≤ 2 %

b: Guaranteed by design, not subject to production testing

7. Typical Characteristics

Power Dissipation

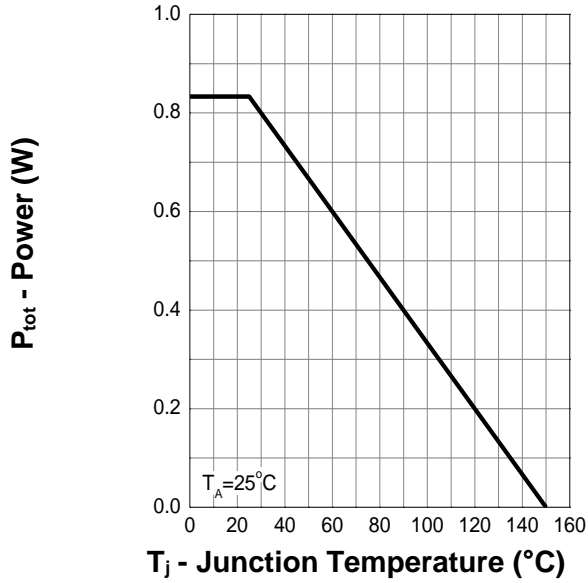

Drain Current

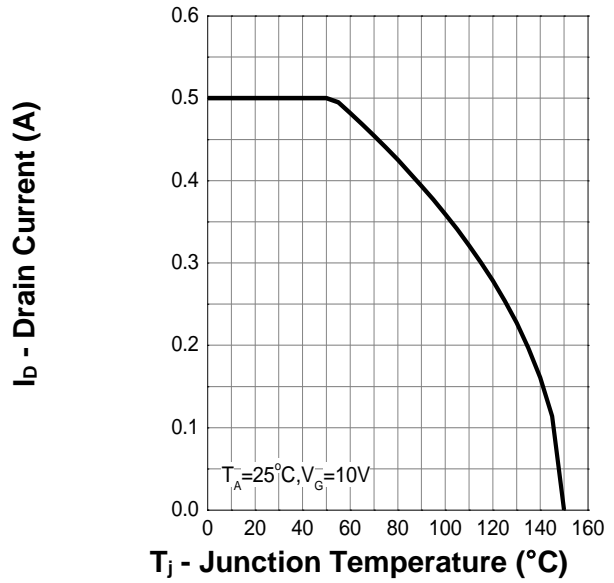

Safe Operatio

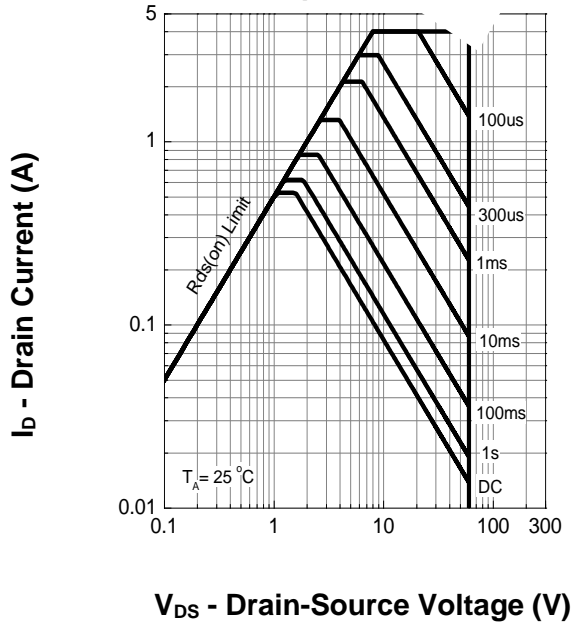

Thermal Transient Impedance

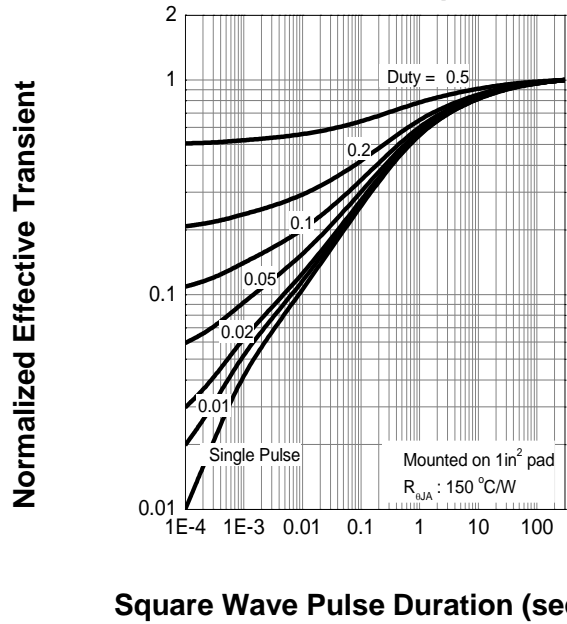

7. Typical Characteristics (cont.)

Output Characteristics

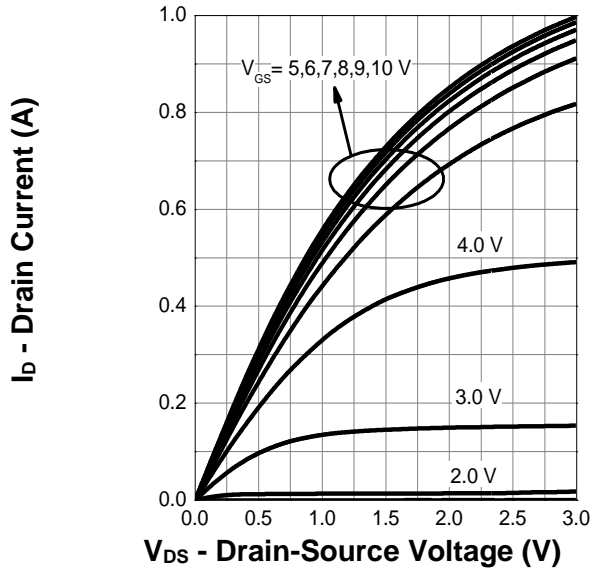

Drain-Source On Resistance

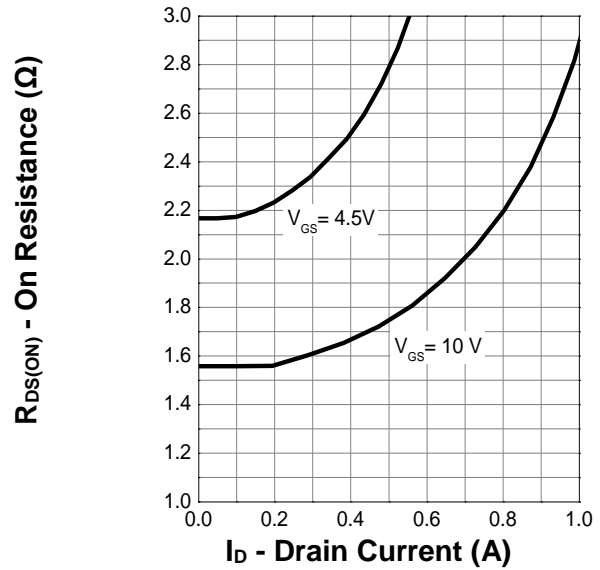

Transfer Characteristics

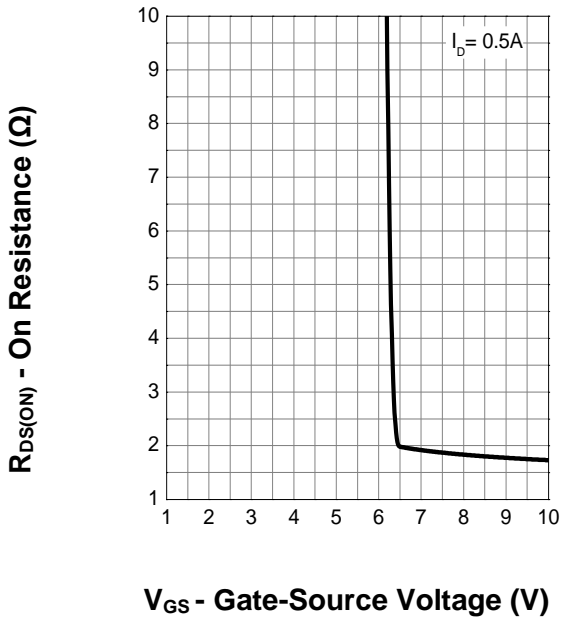

Gate Threshold Voltage

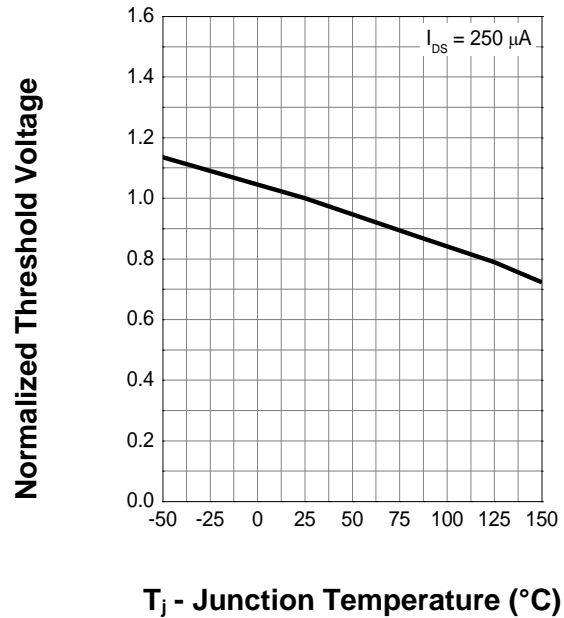

7. Typical Characteristics (cont.)

Drain-Source On Resistance

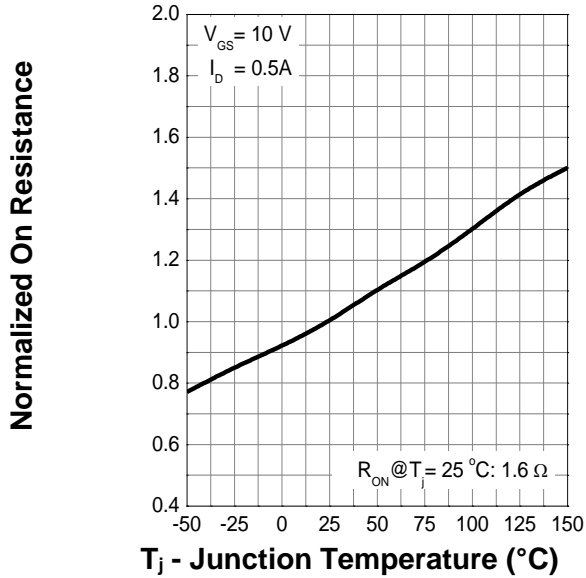

Source-Drain Diode Forward

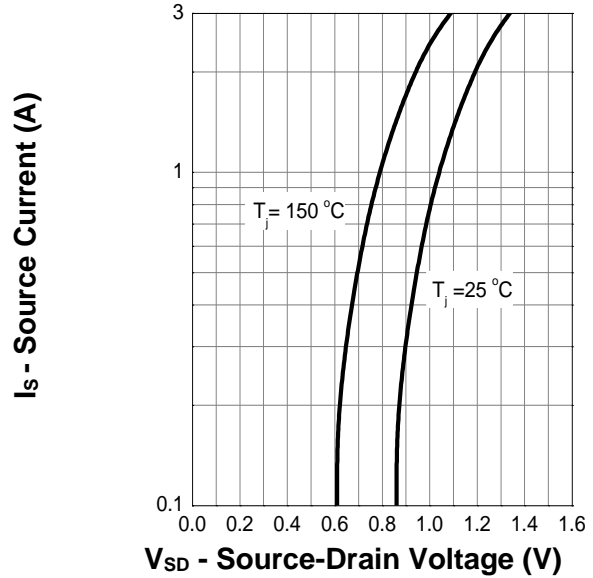

Capacitance

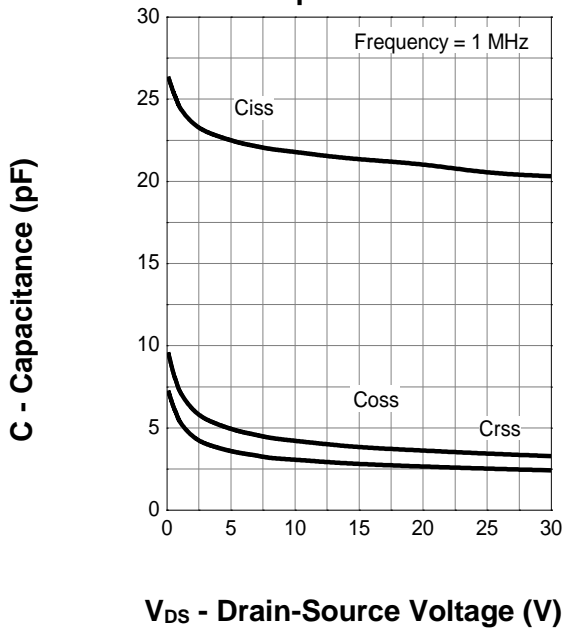

Gate Charge

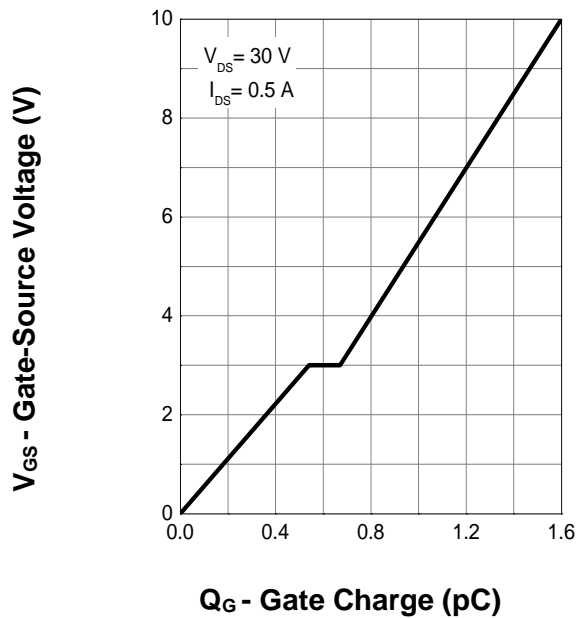

8. Package Dimensions

SOT-723 Package

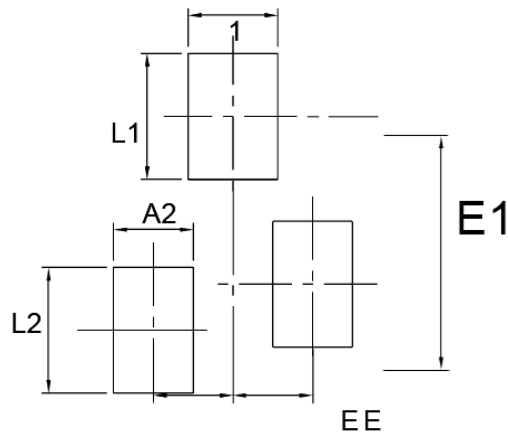
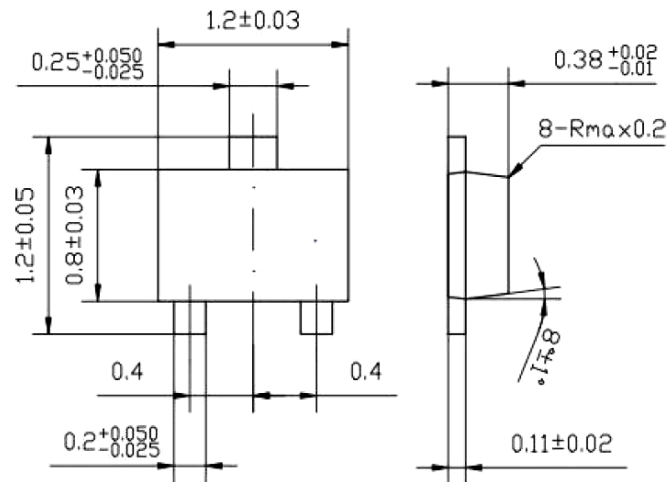

Symbol	A1	A2	L1	L2	E1	E
Dimensions	0.45mm	0.40mm	0.63mm	0.63mm	1.17mm	0.40mm