

P-Channel Enhancement Mode MOSFET

1. Product Information

1.1 Features

- Advanced trench cell design
- Low Thermal Resistance

1.2 Applications

- Motor drivers
- DC-DC Converter

1.3 Quick reference

- $BV \geq -60V$
- $R_{DS(ON)} \leq 12m\Omega @ V_{GS} = -10V$
- $P_{tot} \leq 156W$
- $R_{DS(ON)} \leq 15m\Omega @ V_{GS} = -4.5V$
- $I_D \leq -90A$

2. Pin Description

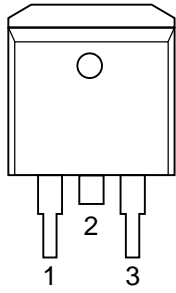
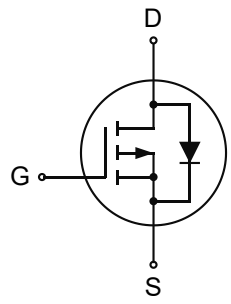
Pin	Description	Simplified Outline	Symbol
1	Gate(G)	 <p>Top View TO-263</p>	
2	Drain(D)		
3	Source(S)		

3. Limiting Values

Symbol	Parameter	Conditions	Min	Max	Unit
V _{DS}	Drain-Source Voltage	T _C =25°C	-60	-	V
V _{GS}	Gate-Source Voltage	T _C =25°C	-	±20	V
I _D ^{*,**,***}	Drain Current	T _C =25°C, V _{GS} =-10V	-	-90	A
		T _C =100°C, V _{GS} =-10V	-	-58	A
I _{DM} ^{*,**,***}	Pulsed Source Current	T _C =25°C, V _{GS} =-10V	-	-120	A
P _{tot} [*]	Total Power Dissipation	T _C =25°C	-	156	W
T _{stg}	Storage Temperature		-55	150	°C
T _J	Junction Temperature		-	150	°C
I _S	Diode Forward Current	T _C =25°C	-	-90	A
R _{θJA} ^{**}	Thermal Resistance-Junction to Ambient		-	62.5	°C/W
R _{θJC} ^{**}	Thermal Resistance-Junction to Case		-	0.8	

Notes :

- * Surface Mounted on 1 in² pad area, t ≤ 10 sec
- ** Pulse width ≤ 10μs, duty cycle ≤ 1%
- *** Limited by bonding wire

4. Marking Information

Product Name	Marking
KJ90P06D	<div style="display: inline-block; border: 1px solid black; padding: 2px;"> 90P06 YWWXXX </div> YWW: Date Code

5. Ordering Code

Product Name	Package	Reel Size	Tape width	Quantity	Note
KJ90P06D	TO-263			800	

Note: KUIJIEXIN defines " Green " as lead-free (RoHS compliant) and halogen free (Br or Cl does not exceed 900 ppm by weight in homogeneous material and total of Br and Cl does not exceed 1500 ppm by weight; Follow IEC 61249-2-21 and IPC / JEDEC J-STD-020C)

6. Electrical Characteristics ($T_A=25^\circ\text{C}$ Unless Otherwise Noted)

Symbol	Parameter	Conditions	Min	Typ	Max	Unit
Static Characteristics						
BV_{DSS}	Drain-Source Breakdown Voltage	$V_{GS}=0V, I_D=-250\mu A$	-60	-	-	V
$V_{GS(th)}$	Gate Threshold Voltage	$V_{DS}=V_{GS}, I_{DS}=-250\mu A$	-1	-	-2.5	V
I_{DSS}	Zero Gate Voltage Source Current	$V_{DS}=-48V, V_{GS}=0V$	-	-	-1	μA
		$T_J=85^\circ\text{C}$	-	-	-30	μA
I_{GSS}	Gate Leakage Current	$V_{GS}=\pm 20V, V_{DS}=0V$	-	-	± 100	nA
$R_{DS(ON)}^a$	Drain-Source On-State Resistance	$V_{GS}=-10V, I_D=-20A$	-	10	12	m Ω
		$V_{GS}=-4.5V, I_D=-10A$	-	12	15	m Ω
Diode Characteristics						
V_{SD}^a	Diode Forward Voltage	$I_{SD}=-20A, V_{GS}=0V$	-	-	-1.3	V
t_{rr}	Reverse Recovery Time	$I_{SD}=-20A, dI_{SD}/dt=100A/\mu s$	-	40	-	ns
Q_{rr}	Reverse Recovery Charge		-	47	-	nC
Dynamic Characteristics ^b						
C_{iss}	Input Capacitance	$V_{GS}=0V, V_{DS}=-30V$ Frequency=1MHz	-	8038	-	pF
C_{oss}	Output Capacitance		-	335	-	
C_{riss}	Reverse Transfer Capacitance		-	144	-	
$t_{d(on)}$	Turn-on Delay Time	$V_{DS}=-30V, V_{GEN}=-10V,$ $R_G=4.5\Omega, R_L=1.5\Omega,$ $I_D=-20A$	-	81	-	ns
t_r	Turn-on Rise Time		-	130	-	
$t_{d(off)}$	Turn-off Delay Time		-	685	-	
t_f	Turn-off Fall Time		-	255	-	
Gate Charge Characteristics ^b						
Q_g	Total Gate Charge	$V_{GS}=-10V, V_{DS}=-30V,$ $I_{DS}=-20A$	-	121	-	nC
Q_{gs}	Gate-Source Charge		-	29	-	
Q_{gd}	Gate-Drain Charge		-	13	-	

Notes:

a: Pulse test ; pulse width $\leq 300\mu s$, duty cycle $\leq 2\%$

b: Guaranteed by design, not subject to production testing

7. Typical Characteristics

Power Capability

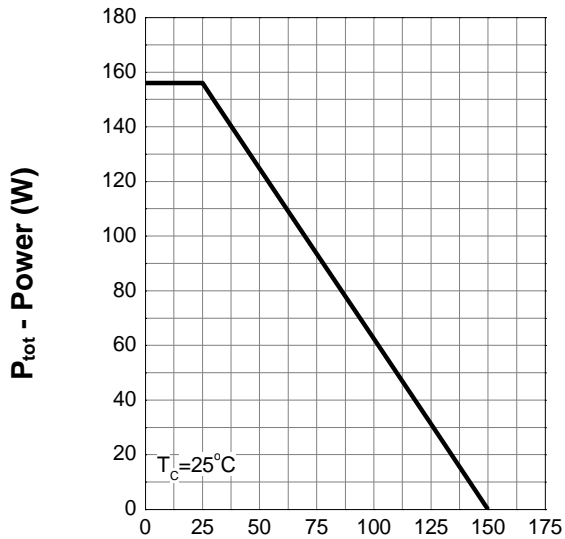

T_j - Junction Temperature (°C)

Current Capability

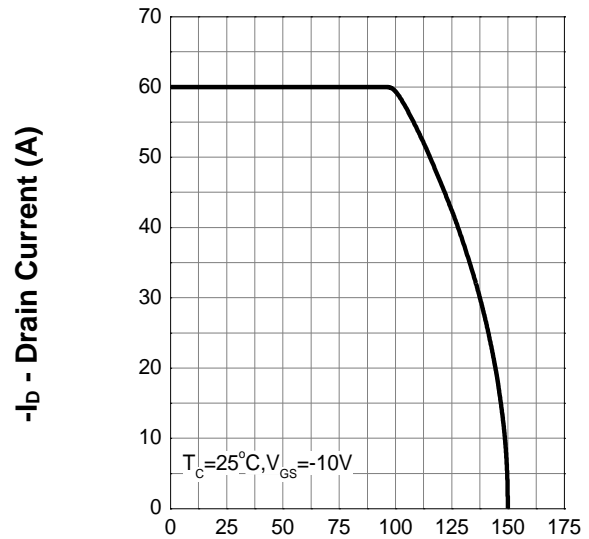

T_j - Junction Temperature (°C)

Safe Operation Area

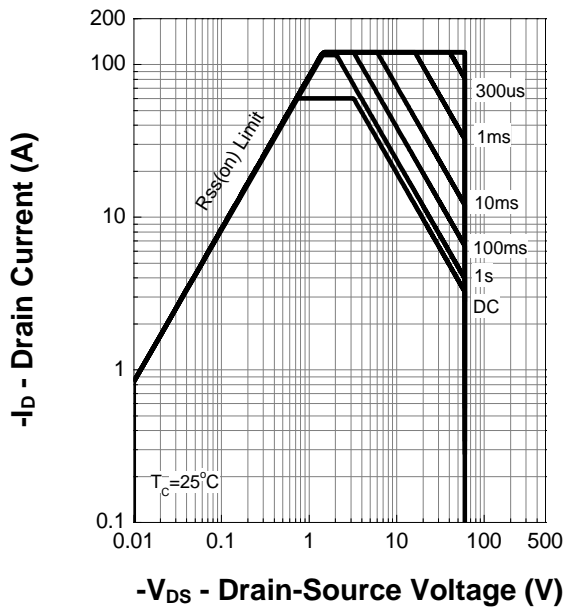

-V_{DS} - Drain-Source Voltage (V)

Thermal Transient Impedance

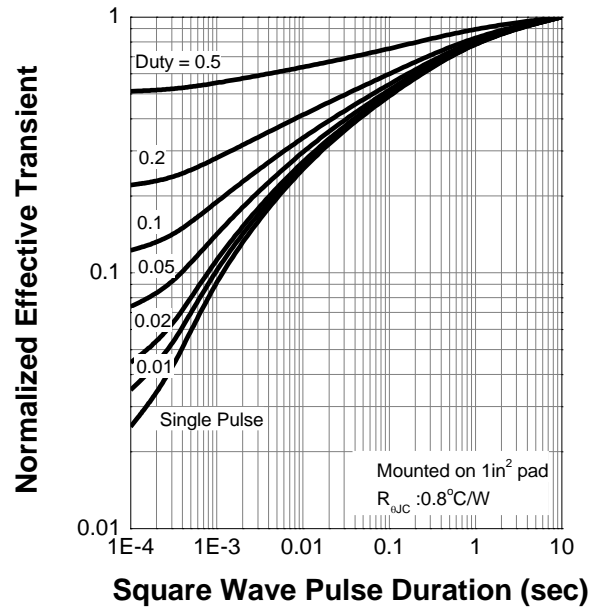

Square Wave Pulse Duration (sec)

7. Typical Characteristics (cont.)

Output Characteristics

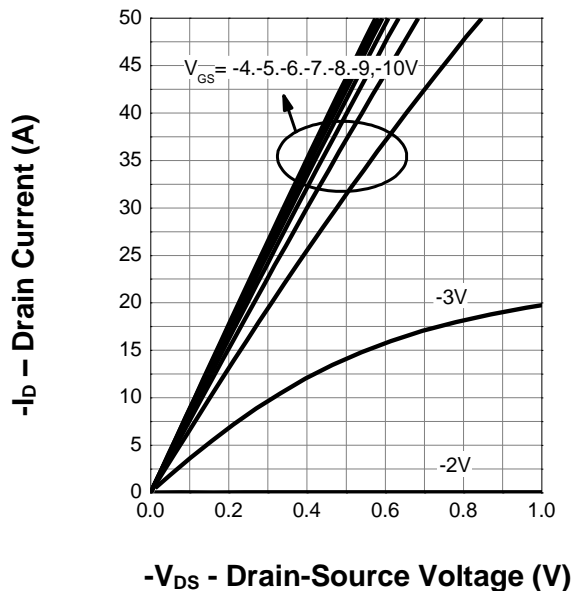

Drain-Source On Resistance

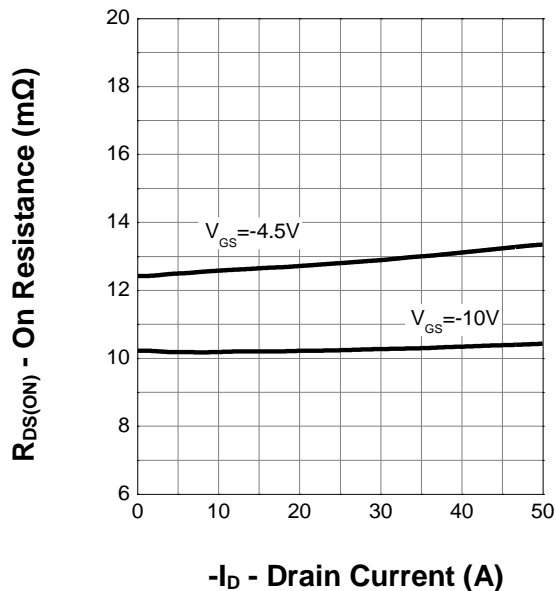

Transfer Characteristics

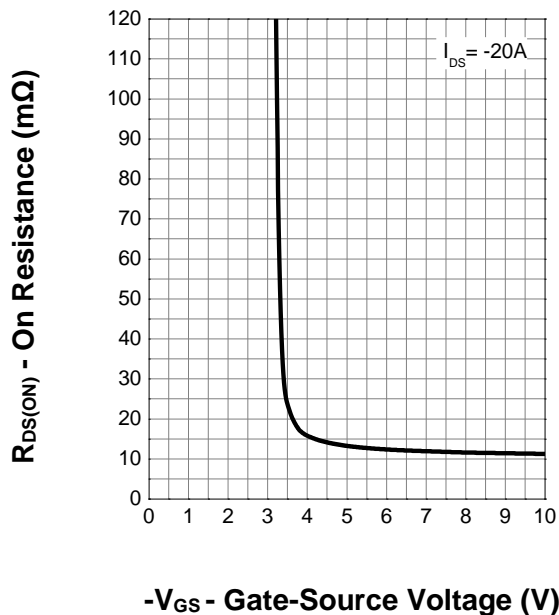

Gate Threshold Voltage

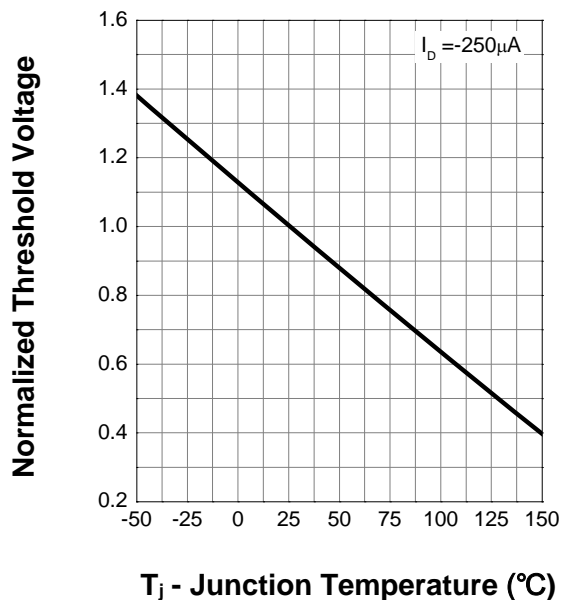

7. Typical Characteristics (cont.)

Drain-Source On Resistance

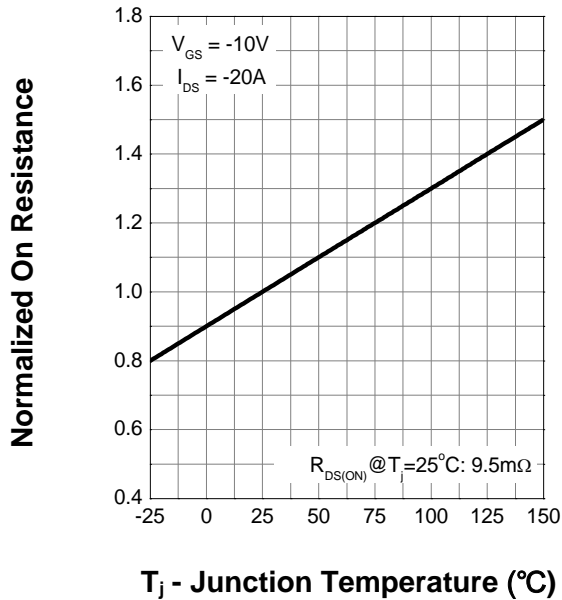

Body Diode Characteristics

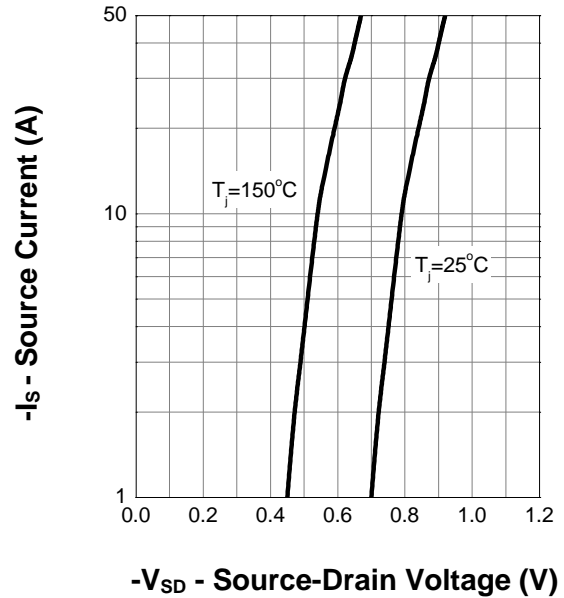

Capacitance

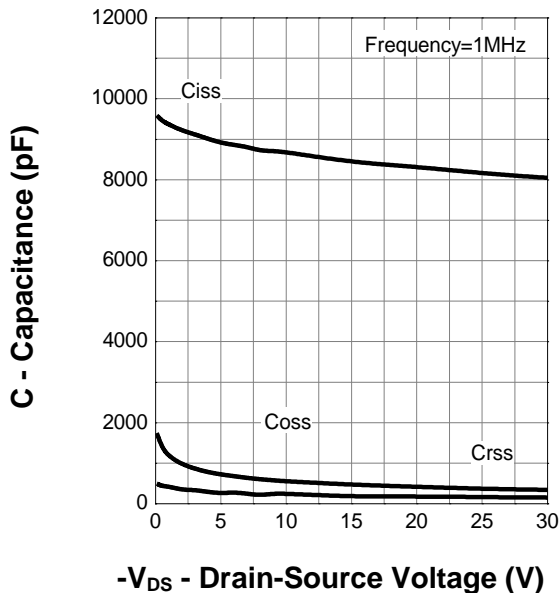

Gate Charge

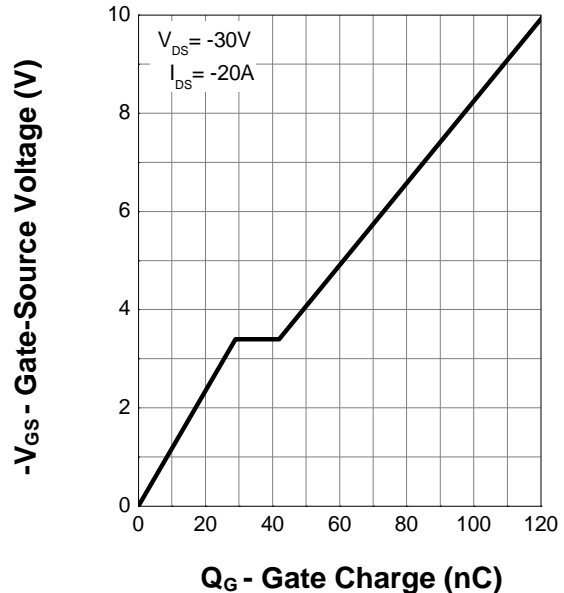

8. Package Dimensions

TO-263 Package

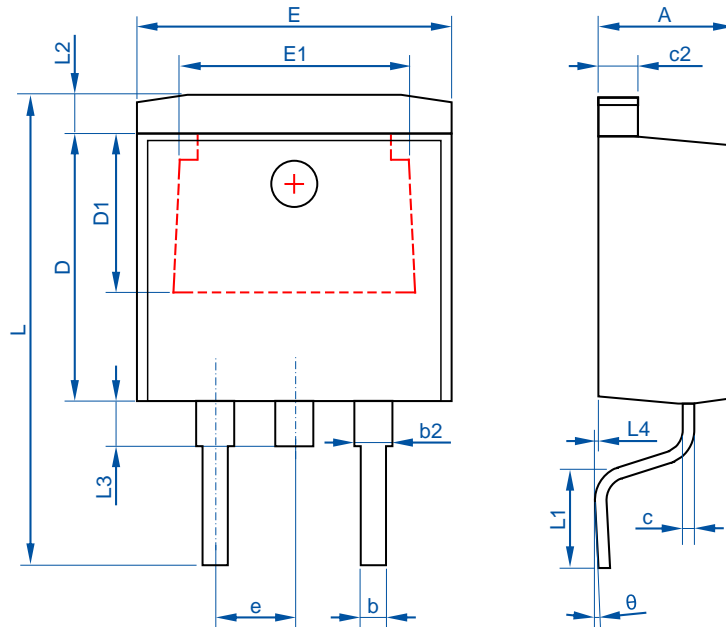

Symbol	Dimensions In Millimeters	
	MIN.	MAX.
A	4.40	4.80
b	0.76	1.00
L4	0.00	0.25
C	0.36	0.50
L3	1.50 REF	
L1	2.29	2.79
E	9.80	10.40
E1	7.40 REF	
c2	1.25	1.45
b2	1.17	1.47
D	8.60	9.00
D1	5.10 REF	
e	2.54 REF	
L	14.60	15.80
θ	$0^\circ \pm 3^\circ$	
L2	1.27 REF	