

Dual N-Channel Enhancement Mode MOSFET

1. Product Information

1.1 Features

- Surface-mounted package
- Low Thermal Resistance

1.2 Applications

- Motor drivers
- DC\DC Converter

1.3 Quick reference

- $BV \leq 30\text{ V}$
- $R_{DS(ON)} \leq 12\text{ m}\Omega @ V_{GS} = 10\text{ V}$
- $P_{tot} \leq 20.8\text{ W}$
- $R_{DS(ON)} \leq 17\text{ m}\Omega @ V_{GS} = 4.5\text{ V}$
- $I_D \leq 34\text{ A}$

2. Pin Description

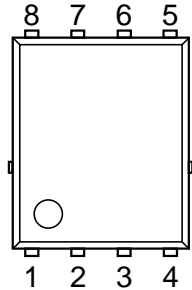
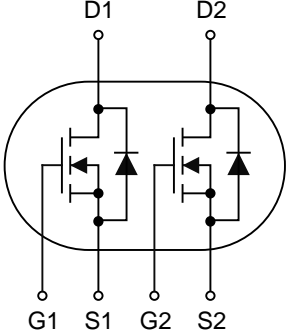
Pin	Description	Simplified Outline	Symbol
1	Source (S1)	 <p>Top View PDFN5x6-8L</p>	
2	Gate (G1)		
3	Source (S2)		
4	Gate (G2)		
5,6	Drain (D2)		
7,8	Drain (D1)		

3. Limiting Values

Symbol	Parameter	Conditions	Min	Max	Unit
V_{DS}	Drain-Source Voltage	$T_C=25^{\circ}C$	30	-	V
V_{GS}	Gate-Source Voltage	$T_C=25^{\circ}C$	-	± 20	V
I_D^*	Drain Current	$T_C=25^{\circ}C, V_{GS}=10\text{ V}$	-	34	A
$I_{DM}^{*,**,***}$	Pulsed Source Current	$T_C=25^{\circ}C, V_{GS}=10\text{ V}$	-	80	A
P_{tot}^*	Total Power Dissipation	$T_C=25^{\circ}C$	-	20.8	W
T_{stg}	Storage Temperature		-55	150	$^{\circ}C$
T_J	Junction Temperature		-	150	$^{\circ}C$
I_S	Diode Forward Current	$T_C=25^{\circ}C$	-	34	A
$R_{\theta JA}^*$	Thermal Resistance-Junction to Ambient		-	62.5	$^{\circ}C/W$
$R_{\theta JC}^*$	Thermal Resistance-Junction to Case		-	6	

Notes :

- * Surface Mounted on 1 in² pad area, $t \leq 10$ sec
- ** Pulse width $\leq 10\ \mu s$, duty cycle $\leq 1\%$
- *** Limited by bonding wire

4. Marking Information

Product Name	Marking
KJ0903DG	<div style="display: flex; align-items: center;"> <div style="background-color: black; color: white; padding: 2px 5px; margin-right: 10px;">0903D YWWXXX</div> <div>YWWXXX: Date Code</div> </div>

5. Ordering Code

Product Name	Package	Reel Size	Tape width	Quantity	Note
KJ0903DG	PDFN5x6-8L			5000	

Note: KUIJIEXIN defines "Green" as lead-free (RoHS compliant) and halogen free (Br or Cl does not exceed 900 ppm by weight in homogeneous material and total of Br and Cl does not exceed 1500 ppm by weight; Follow IEC 61249-2-21 and IPC/JEDEC J-STD-020C)

6. Electrical Characteristics (T_A=25°C Unless Otherwise Noted)

Symbol	Parameter	Conditions	Min	Typ	Max	Unit
Static Characteristics						
B _{VDS}	Drain-Source Breakdown Voltage	V _{GS} =0 V, I _D =250 μA	30	-	-	V
V _{GS(th)}	Gate Threshold Voltage	V _{DS} =V _{GS} , I _{DS} =250 μA	0.8	-	1.6	V
I _{DSS}	Zero Gate Voltage Source Current	V _{DS} =24, V _{GS} =0 V	-	-	1	μA
		T _J =85°C	-	-	30	μA
I _{GSS}	Gate Leakage Current	V _{GS} =±20 V, V _{DS} =0 V	-	-	±100	nA
R _{DS(ON)} ^a	Drain-Source On-State Resistance	V _{GS} =10 V, I _D =20 A	-	10	12	mΩ
		V _{GS} =4.5 V, I _D =10 A	-	15	17	
Diode Characteristics						
V _{SD} ^a	Diode Forward Voltage	I _{SD} =20 A, V _{GS} =0 V	-	-	1.3	V
t _{rr}	Reverse Recovery Time	I _{SD} =20 A, dI _{SD} /dt=100 A/μs	-	16	-	ns
Q _{rr}	Reverse Recovery Charge		-	7	-	nC
Dynamic Characteristics^b						
C _{iss}	Input Capacitance	V _{GS} =0 V, V _{DS} =15 V Frequency=1 MHz	-	918	-	pF
C _{oss}	Output Capacitance		-	114	-	
C _{rss}	Reverse Transfer Capacitance		-	101	-	
t _{d(on)}	Turn-on Delay Time	V _{DS} =15 V, V _{GEN} =10 V, R _G =4.5 Ω, R _L =0.75 Ω, I _D =20 A	-	7	-	ns
t _r	Turn-on Rise Time		-	55	-	
t _{d(off)}	Turn-off Delay Time		-	19	-	
t _f	Turn-off Fall Time		-	23	-	
Gate Charge Characteristics^b						
Q _g	Total Gate Charge	V _{GS} =10 V, V _{DS} =15 V, I _{DS} =20 A	-	20	-	nC
Q _{gs}	Gate-Source Charge		-	3.6	-	
Q _{gd}	Gate-Drain Charge		-	3.9	-	

Notes :

- a: Pulse test; pulse width ≤ 300 μs, duty cycle ≤ 2%
- b: Guaranteed by design, not subject to production testing

7. Typical Characteristics (Cont.)

Power Capability

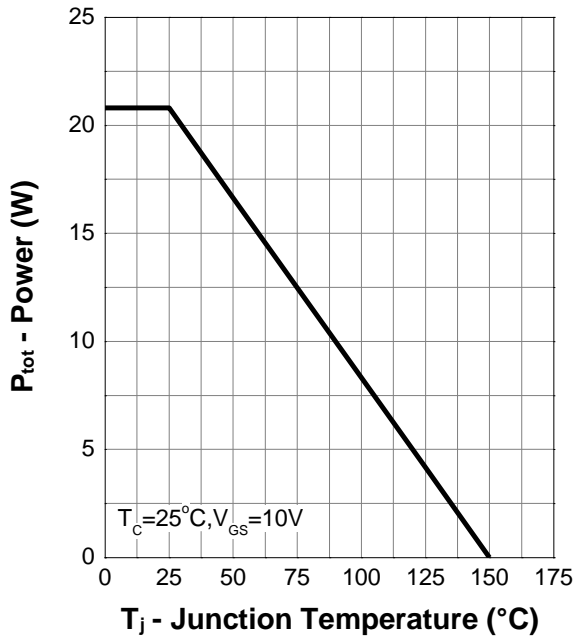

Current Capability

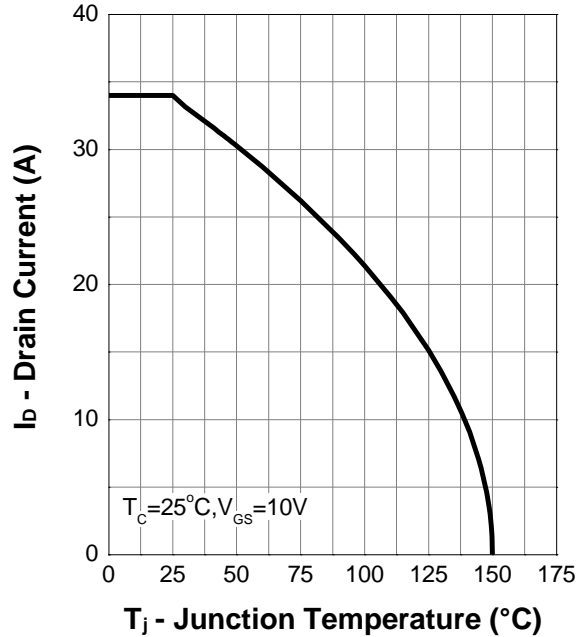

Safe Operation Area

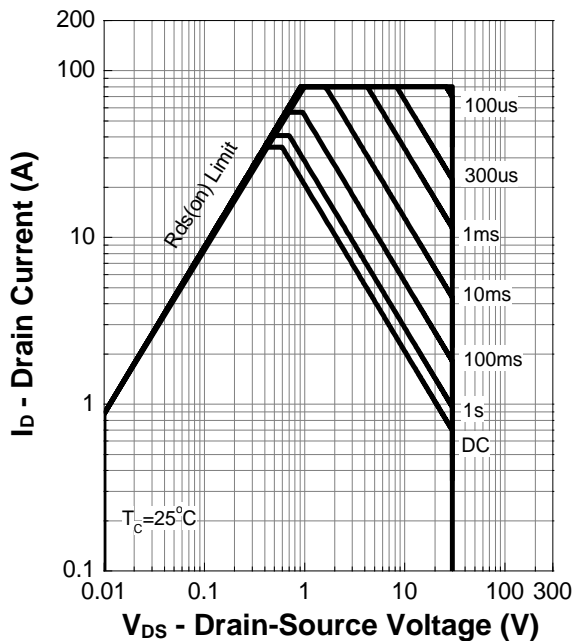

Transient Thermal Impedance

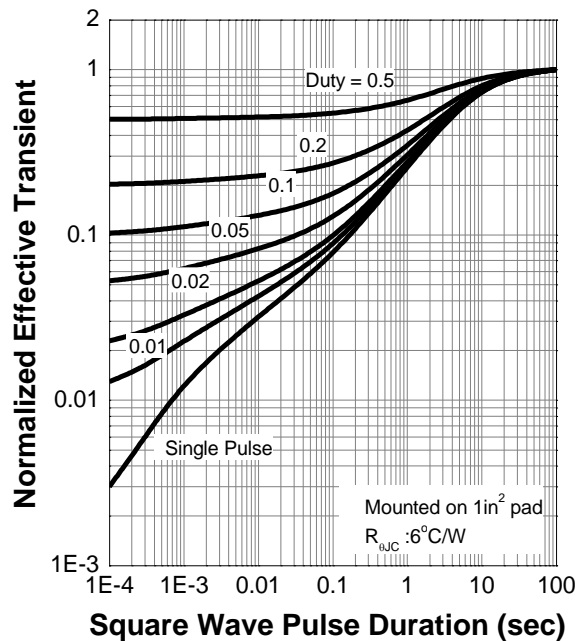

7. Typical Characteristics (Cont.)

Output Characteristics

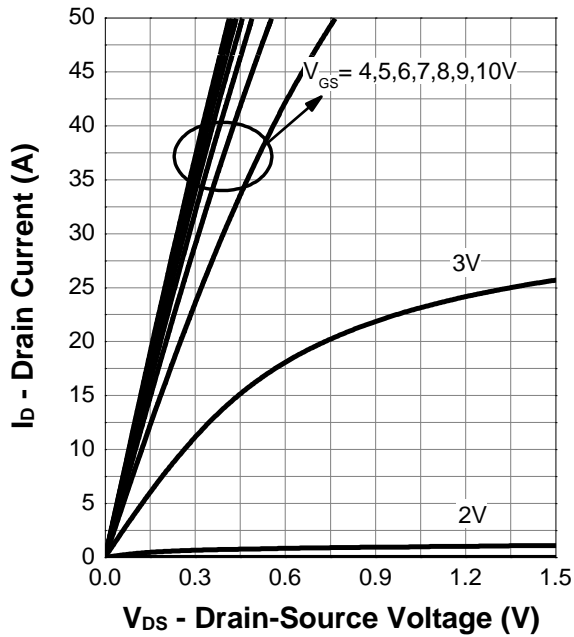

On Resistance

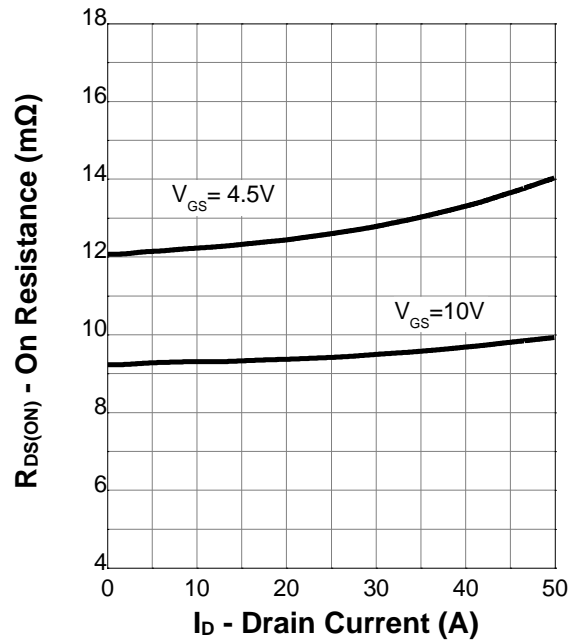

Transfer Characteristics

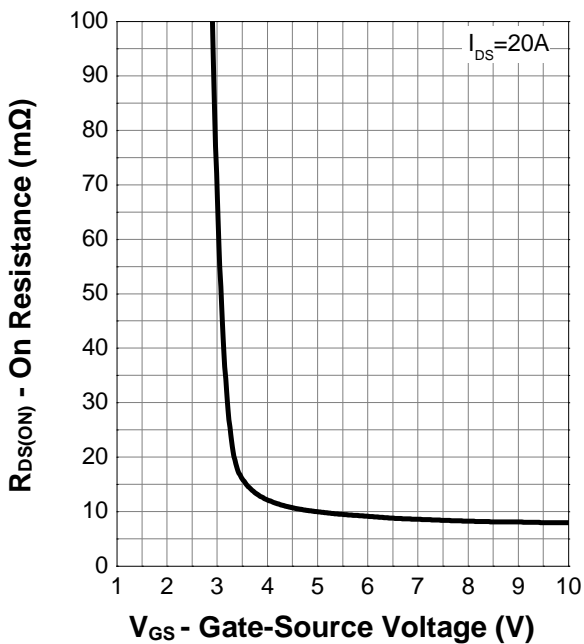

Normalized Threshold Voltage

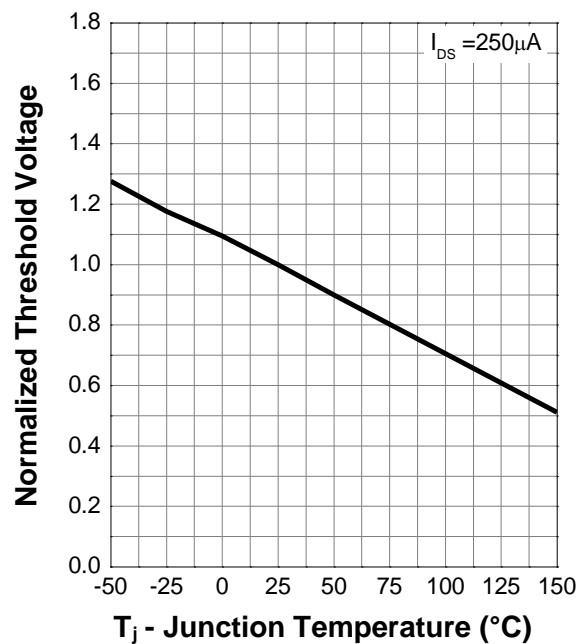

7. Typical Characteristics (Cont.)

Normalized On Resistance

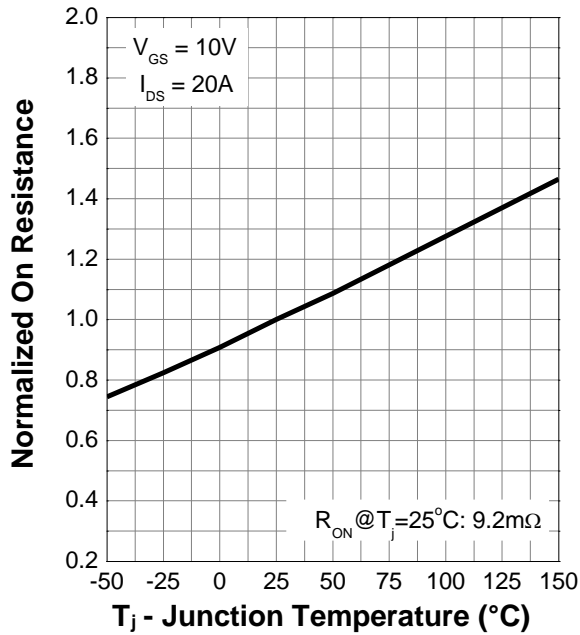

Diode Forward Current

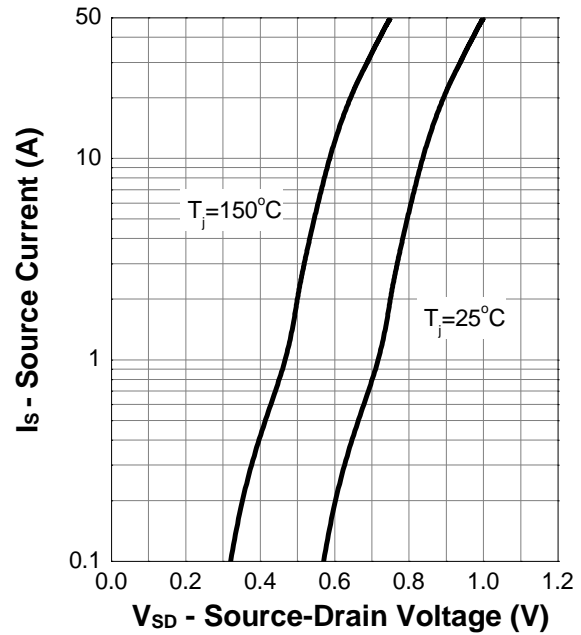

Capacitance

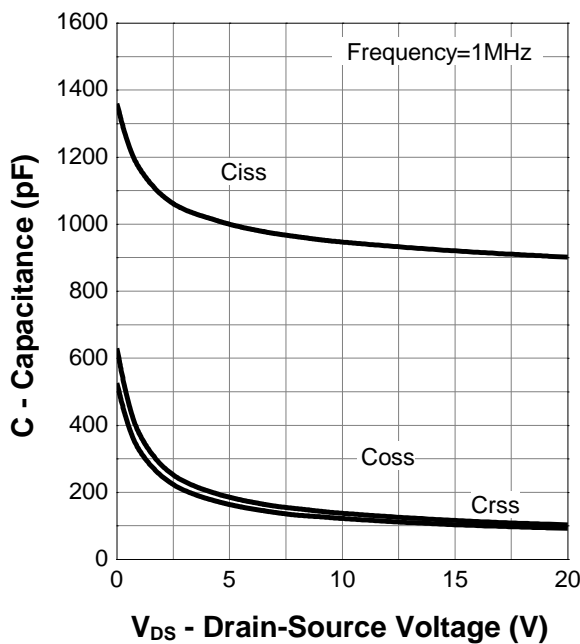

Gate Charge

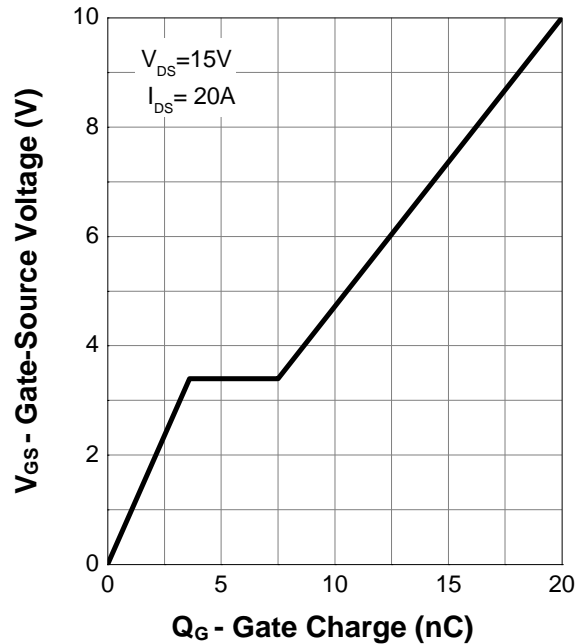

8. Package Dimensions

PDFN5x6-8L Package

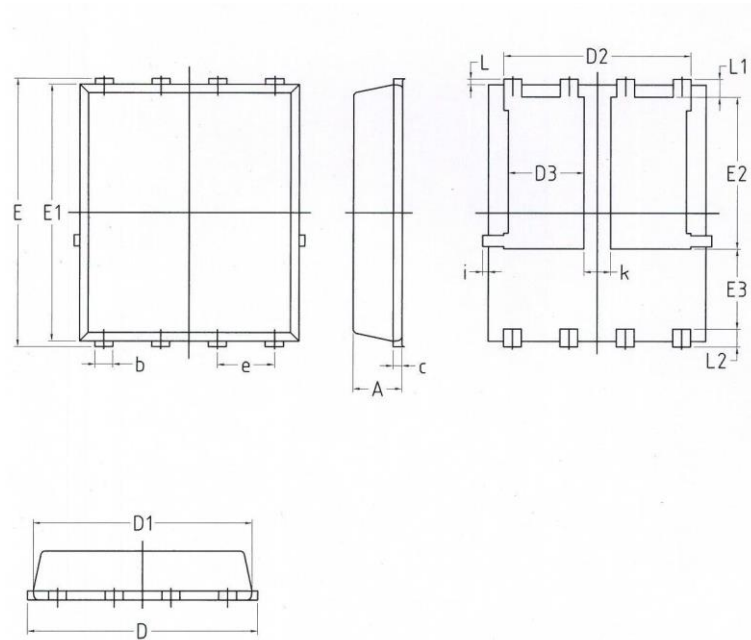

Symbol	Dimensions In Millimeters	
	MIN.	MAX.
A	1.03	1.17
B	0.34	0.48
c	0.203 BSC	
D	4.80	5.40
D1	4.80	5.00
D2	4.11	4.31
D3	1.60	1.80
E	5.95	6.15
E1	5.65	5.85
E2	3.30	3.50
E3	1.70	-
e	1.27 BSC	
L	0.05	0.25
L1	0.38	0.5
L2	0.38	0.5
i	-	0.18
k	0.5	0.7