

N-Channel Enhancement Mode MOSFET

1. Product Information

Features

Ultra Low Gate Charge (Typ. 15 nC)
Fast Switching Capability
Avalanche Energy Specified

Pin Description

Pin	Description
1	Gate(G)
2	Drain(D)
3	Source(S)

Applications

High frequency switching mode power supply
LED power supplies
Electronic ballast

Quick reference

$V_{DS} = 700\text{ V}$
 $I_D = 4\text{ A}$
 $R_{DS(ON)} \leq 2.8\ \Omega @ V_{GS}=10\text{V (Typ. } 2.6\ \Omega)$

Simplified Outline

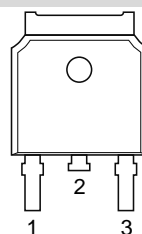

Top View
TO-252

Symbol

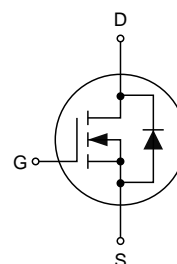

Package Marking and Ordering Information

Product Name	Package	Marking	Reel Size	Tape Width	Quantity
KJ4N70K	TO-252	KJ4N70K	-	-	2500

2. Absolute Maximum Ratings (T_C=25°C unless otherwise noted)

Symbol	Parameter	Values	Unit
V _{DS}	Drain-Source Voltage	700	V
V _{GS}	Gate-Source Voltage	±30	V
I _{AR}	Avalanche Current ²	4.0	A
I _D	Drain Current Continuous	4.0	A
I _{DM}	Pulsed Drain Current ²	17.6	A
E _{AS}	Avalanche Energy Single Pulsed ³	216	mJ
E _{AR}	Avalanche Energy Repetitive ²	10.6	mJ
P _D	Power Dissipation (TO-220)	106	W
	Power Dissipation (TO-220F)	36	W
Dv/dt	Peak Diode Recovery dv/dt ⁴	45	V/ns
T _J , T _{STG}	Operating Junction and Storage Temperature Range	-55~150	°C
R _{θJA}	Thermal Resistance from Junction to Ambient	62.5	°C/W
R _{θJC}	Thermal Resistance from Junction to Case	1.6	°C/W

3. Electrical Characteristics (T_C=25°C, unless otherwise noted)

Symbol	Parameter	Test Conditions	Min.	Typ.	Max.	Unit
BV _{DSS}	Drain-Source Breakdown Voltage	V _{GS} =0 V, I _D =250 μA	700	-	-	V
V _{GS(th)}	Gate-Threshold Voltage	V _{DS} =V _{GS} , I _D =250 μA	2.0	-	4.0	V
I _{GSS}	Gate-Source Leakage Current	V _{DS} =0 V, V _{GS} =±30 V	-	-	±100	nA
I _{DSS}	Drain-Source Leakage Current	V _{DS} =700 V, V _{GS} =0 V	-	-	10	μA
ΔBV _{DSS} /ΔT _J	Breakdown Voltage Temperature Coefficient	I _D = 250 μA, Referenced to 25°C	-	0.6	-	V/°C
R _{DS(on)}	Static Drain-Source On-Resistance ²	V _{GS} =10 V, I _D =2 A	-	2.6	2.8	Ω
C _{iss}	Input Capacitance	V _{DS} =25 V, V _{GS} =0 V, f=1.0 MHz	-	520	670	pF
C _{oss}	Output Capacitance		-	70	90	
C _{rss}	Reverse Transfer Capacitance		-	8	11	
Q _g	Total Gate Charge	V _{DS} =560 V, V _{GS} =10 V, I _D =4 A ^{5,6}	-	15	20	nC
Q _{gs}	Gate-Source Charge		-	3.4	-	
Q _{gd}	Gate-Drain Charge		-	7.1	-	
t _{d(on)}	Turn-on Delay Time	V _{DD} =350 V, V _{GS} =10 V, I _D =4 A, R _G =25 Ω ^{5,6}	-	13	35	ns
t _r	Turn-on Rise Time		-	45	100	
t _{d(off)}	Turn-off Delay Time		-	25	60	
t _f	Turn-off Fall Time		-	35	80	
V _{SD}	Diode Forward Voltage	V _{GS} =0 V, I _S =4 A	-	-	1.4	V
I _S	Maximum Continuous Drain-Source Diode Forward Current		-	-	4	A
I _{SM}	Maximum Pulsed Drain-Source Diode Forward Current		-	-	16	A
t _{rr}	Reverse Recovery Time	V _{GS} =0 V, I _S =4 A, di/dt=100A/μs ⁵	-	250	-	ns
Q _{rr}	Reverse Recovery Charge		-	1.5	-	uC

Notes:

1. Absolute maximum ratings are those values beyond which the device could be permanently damaged. Absolute maximum ratings are stress ratings only and functional device operation is not implied.
2. Repetitive Rating: Pulse width limited by maximum junction temperature
3. L=27 mH, I_{AS}=4 A, V_{DD}=50 V, R_G=25 Ω, Starting T_J=25°C
4. I_{SD}≤4.0 A, di/dt≤200 A/μs, V_{DD}≤BV_{DSS}, Starting T_J=25°C
5. Pulse Test: Pulse width≤300 μs, Duty cycle≤2%
6. Essentially independent of operating temperature

4. Typical Characteristics

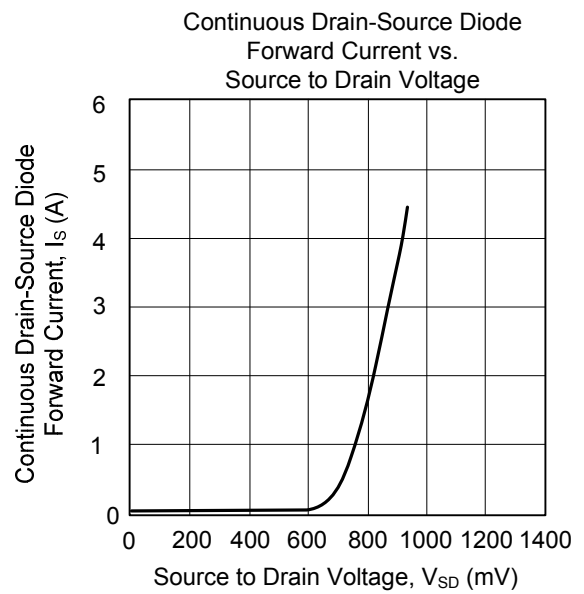
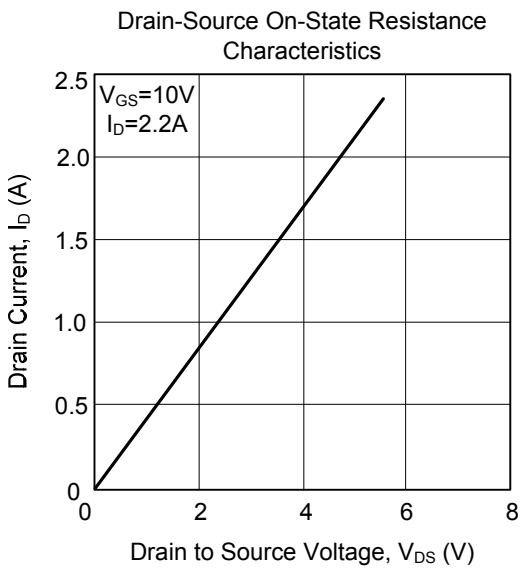
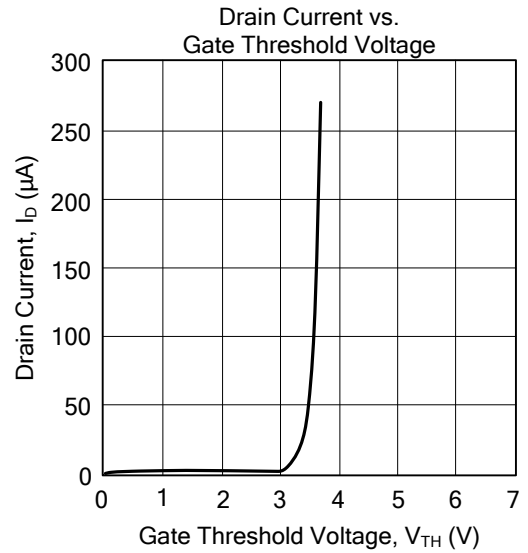
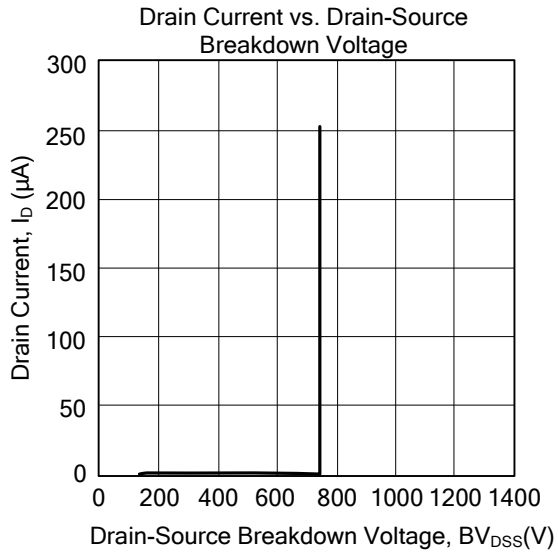

5. Test Circuits and Waveforms

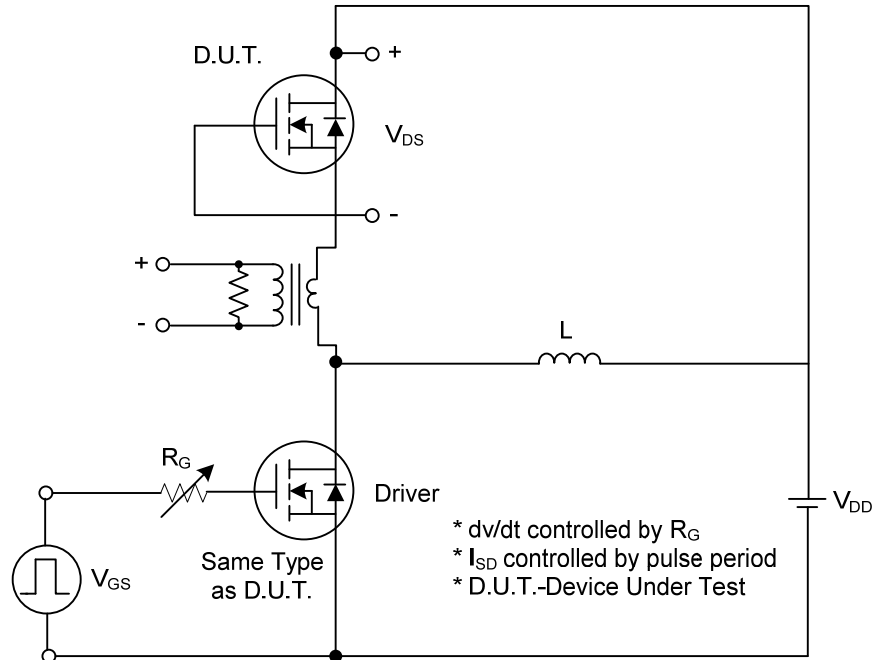

Peak Diode Recovery dv/dt Test Circuit

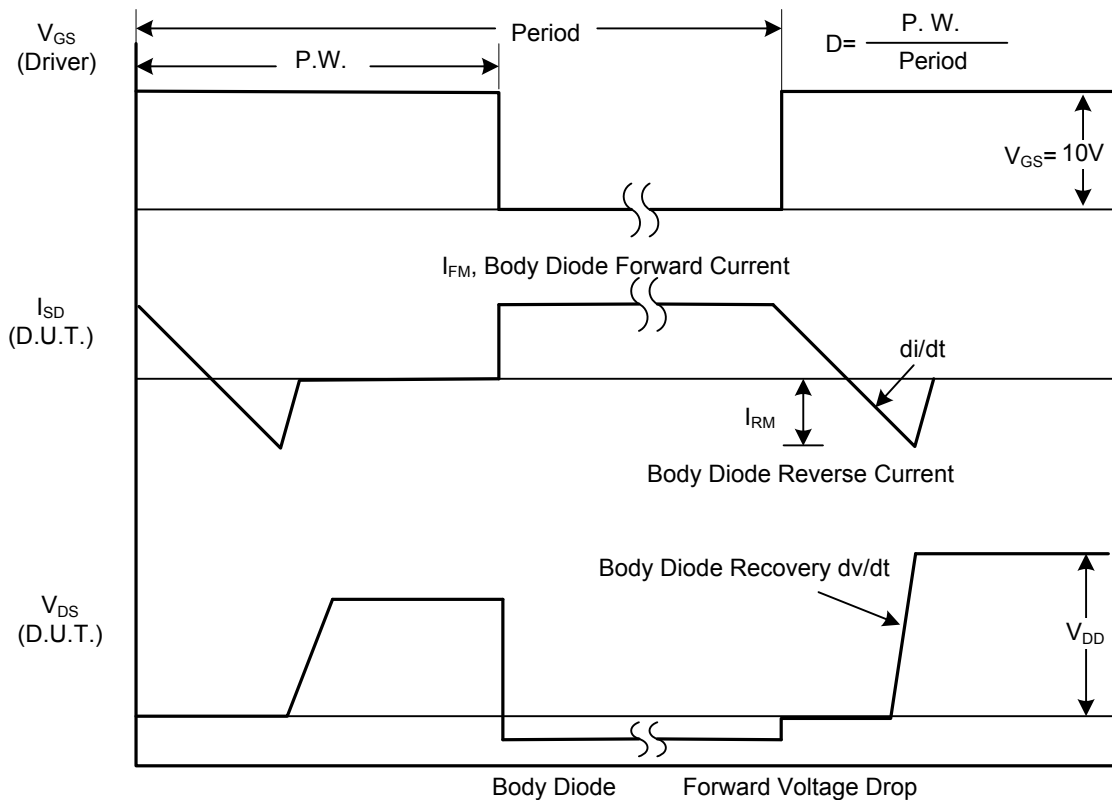

Peak Diode Recovery dv/dt Waveforms

5. Test Circuits and Waveforms (Cont.)

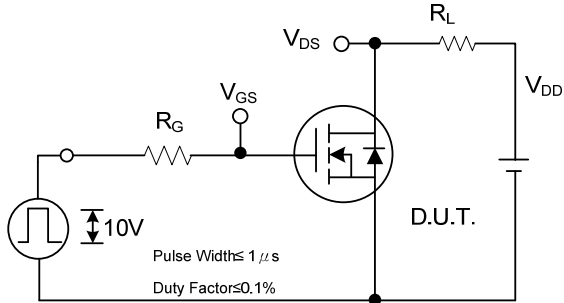

Switching Test Circuit

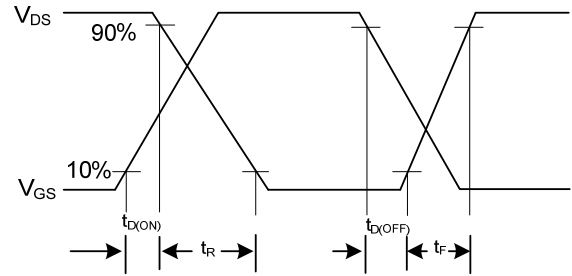

Switching Waveforms

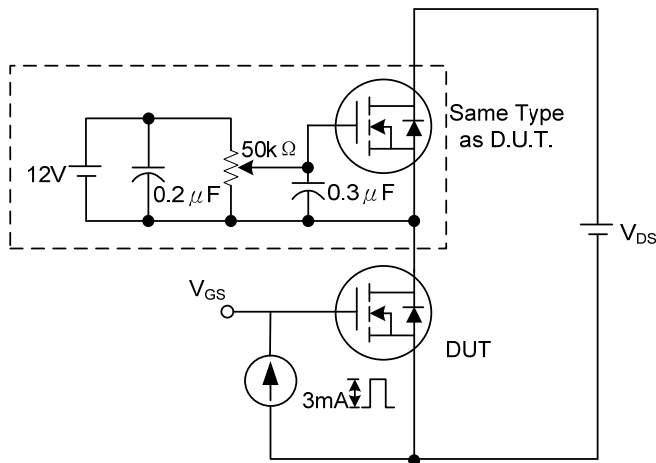

Gate Charge Test Circuit

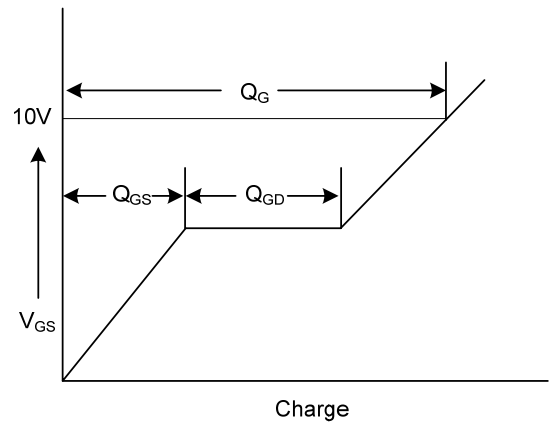

Gate Charge Waveform

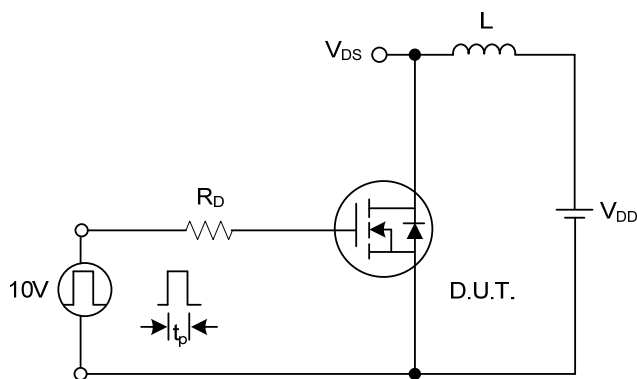

Unclamped Inductive Switching Test Circuit

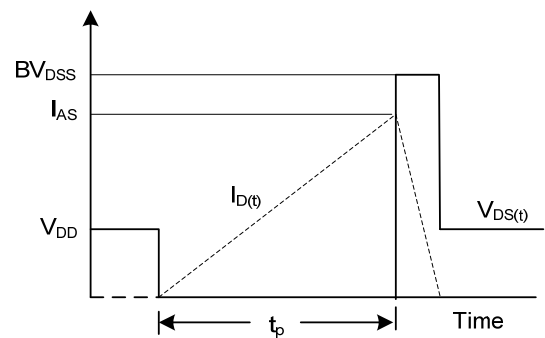

Unclamped Inductive Switching Waveforms

6. Package Mechanical Data

TO-252 Package

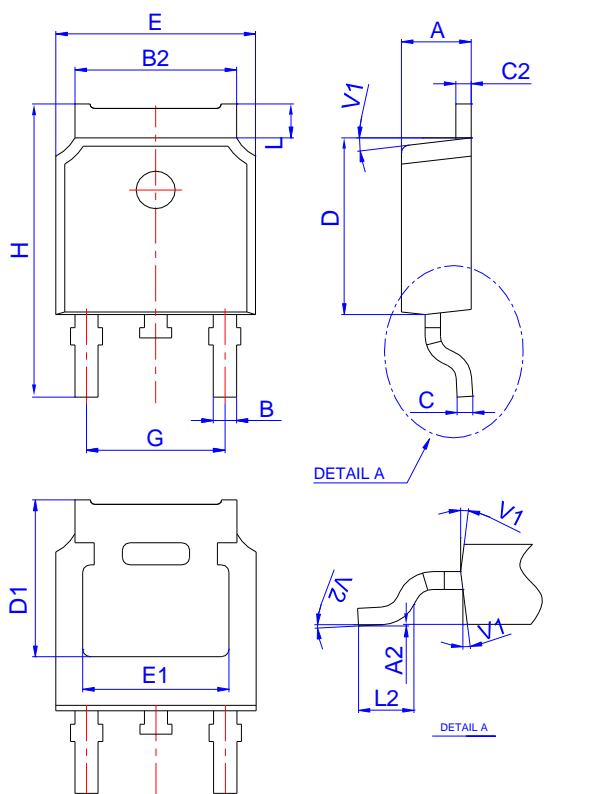

Ref.	Dimensions					
	Millimeters			Inches		
	Min.	Typ.	Max.	Min.	Typ.	Max.
A	2.10		2.50	0.083		0.098
A2	0.00		0.10	0		0.004
B	0.66		0.86	0.026		0.034
B2	5.18		5.48	0.202		0.216
C	0.40		0.60	0.016		0.024
C2	0.44		0.58	0.017		0.023
D	5.90		6.30	0.232		0.248
D1	5.30 REF			0.209 REF		
E	6.40		6.80	0.252		0.268
E1	4.63			0.182		
G	4.47		4.67	0.176		0.184
H	9.50		10.70	0.374		0.421
L	1.09		1.21	0.043		0.048
L2	1.35		1.65	0.053		0.065
V1		7°			7°	
V2	0°		6°	0°		6°

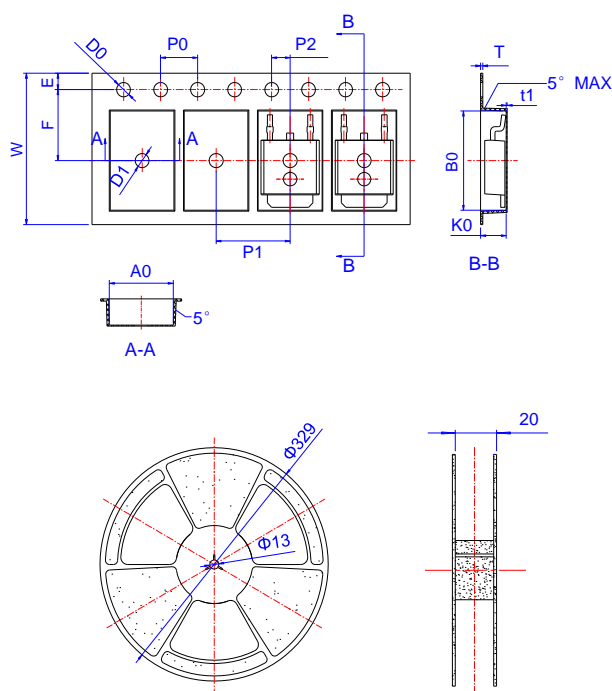

Ref.	Dimensions					
	Millimeters			Inches		
	Min.	Typ.	Max.	Min.	Typ.	Max.
W	15.9	16	16.1	0.626	0.630	0.634
E	1.65	1.75	1.85	0.065	0.069	0.073
F	7.4	7.5	7.6	0.291	0.295	0.299
D0	1.4	1.5	1.6	0.055	0.059	0.063
D1	1.4	1.5	1.6	0.055	0.059	0.063
P0	3.9	4	4.1	0.154	0.157	0.161
P1	7.9	8	8.1	0.311	0.315	0.319
P2	1.9	2	2.1	0.075	0.079	0.083
A0	6.85	6.9	7	0.270	0.271	0.276
B0	10.45	10.5	10.6	0.411	0.413	0.417
K0	2.68	2.78	2.88	0.105	0.109	0.113
T	0.24		0.27	0.009		0.011
t1	0.10			0.004		
10P0	39.8	40	40.2	1.567	1.575	1.583