

N-Channel Enhancement Mode MOSFET

1. Product Information

1.1 Features

- Surface-mounted package
- Advanced trench cell design

1.2 Applications

- Portable appliances
- Battery management
- High speed switch
- Low power DC to DC Converter

1.3 Quick reference

- $BV \geq 30\text{ V}$
- $R_{DS(ON)} \leq 26\text{ m}\Omega @ V_{GS} = 10\text{ V}$
- $P_{tot} \leq 0.71\text{ W}$
- $R_{DS(ON)} \leq 30\text{ m}\Omega @ V_{GS} = 4.5\text{ V}$
- $I_D \leq 5\text{ A}$
- $R_{DS(ON)} \leq 45\text{ m}\Omega @ V_{GS} = 2.5\text{ V}$

2. Pin Description

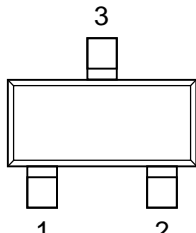
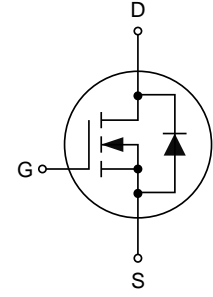
Pin	Description	Simplified Outline	Symbol
1	Gate (G)	 <p>Top View SOT23</p>	
2	Source (S)		
3	Drain (D)		

3. Limiting Values

Symbol	Parameter	Conditions	Min	Max	Unit
V_{DS}	Drain-Source Voltage	$T_A = 25^\circ\text{C}$	30	-	V
V_{GS}	Gate-Source Voltage	$T_A = 25^\circ\text{C}$	-	± 12	V
I_D^*	Drain Current	$T_A = 25^\circ\text{C}, V_{GS} = 10\text{ V}$	-	5.0	A
$I_{DM}^{*,**}$	Pulsed Drain Current	$T_A = 25^\circ\text{C}, V_{GS} = 10\text{ V}$	-	20	A
P_{tot}	Total Power Dissipation	$T_A = 25^\circ\text{C}$	-	0.72	W
T_J, T_{stg}	Operating Junction and Storage Temperature		-55	150	$^\circ\text{C}$
I_S	Diode Forward Current	$T_A = 25^\circ\text{C}$	-	5.0	A
$R_{\theta JA}^*$	Thermal Resistance-Junction to Ambient		-	140	$^\circ\text{C/W}$

Notes :

- * Surface Mounted on 1 in² pad area, $t \leq 10\text{ sec}$
- ** Pulse width $\leq 300\ \mu\text{s}$, duty cycle $\leq 2\%$

4. Marking Information

Product Name	Marking
KJ3400S	3400

5. Ordering Code

Product Name	Package	Reel Size	Tape width	Quantity	Note
KJ3400S	SOT23	7 inch		3000	

Note: KUIJIEXIN defines "Green" as lead-free (RoHS compliant) and halogen free (Br or Cl does not exceed 900 ppm by weight in homogeneous material and total of Br and Cl does not exceed 1500 ppm by weight; Follow IEC 61249-2-21 and IPC/JEDEC J-STD-020C)

6. Electrical Characteristics (T_A=25°C Unless Otherwise Noted)

Symbol	Parameter	Conditions	Min	Typ	Max	Unit
Static Characteristics						
B _V DSS	Drain-Source Breakdown Voltage	V _{GS} = 0 V, I _{DS} = 250 μA	30	-	-	V
V _{GS(th)}	Gate Threshold Voltage	V _{DS} = V _{GS} , I _{DS} = 250 μA	0.5	0.9	1.5	V
I _{DSS}	Drain Leakage Current	V _{DS} = 24 V, V _{GS} = 0 V	-	-	1	μA
		T _J = 85°C	-	-	30	μA
I _{GSS}	Gate Leakage Current	V _{GS} = ±12 V, V _{DS} = 0 V	-	-	±100	nA
R _{DS(ON)} ^a	On-State Resistance	V _{GS} = 10 V, I _{DS} = 5 A	-	21	26	mΩ
		V _{GS} = 4.5 V, I _{DS} = 4.5 A	-	25	30	
		V _{GS} = 2.5 V, I _{DS} = 4.0 A	-	35	45	
Dynamic Characteristics^b						
C _{iss}	Input Capacitance	V _{GS} = 0 V, V _{DS} = 15 V Frequency = 1 MHz	-	630	-	pF
C _{oss}	Output Capacitance		-	76	-	
C _{rss}	Reverse Transfer Capacitance		-	55	-	
t _{d(on)}	Turn-on Delay Time	V _{DS} = 15 V, V _{GEN} = 10 V, R _G = 3 Ω, R _L = 2.6 Ω	-	3	-	ns
t _r	Turn-on Rise Time		-	25	-	
t _{d(off)}	Turn-off Delay Time		-	25	-	
t _f	Turn-off Fall Time		-	4	-	
Gate Charge Characteristics^b						
Q _g	Total Gate Charge	V _{GS} = 4.5 V, V _{DS} = 15 V, I _{DS} = 5 A	-	6	-	nC
Q _{gs}	Gate-Source Charge		-	1.3	-	
Q _{gd}	Gate-Drain Charge		-	1.8	-	
Diode Characteristics						
V _{SD} ^a	Diode Forward Voltage	I _{SD} = 1A, V _{GS} = 0 V	-	0.72	1.2	V

Notes : a: Pulse test ; pulse width ≤ 300 μs, duty cycle ≤ 2%

b: Guaranteed by design, not subject to production testing

7. Typical Characteristics

Power Capability

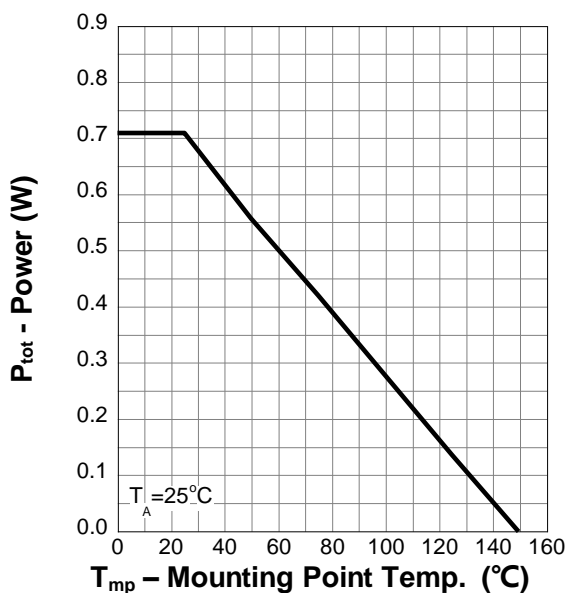

Current Capability

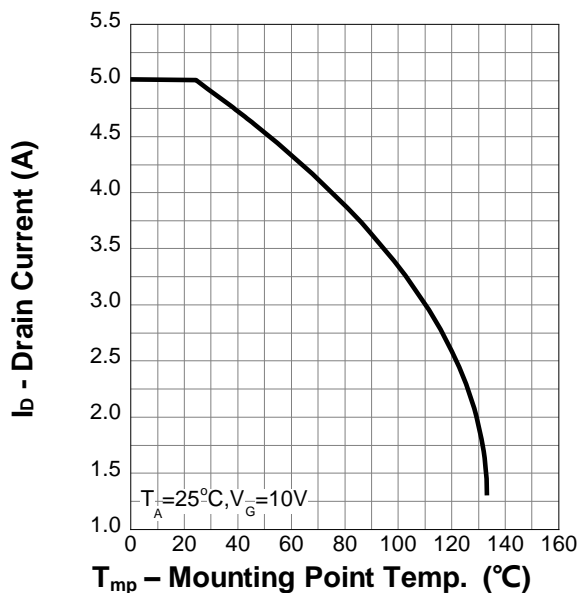

Safe Operation Area

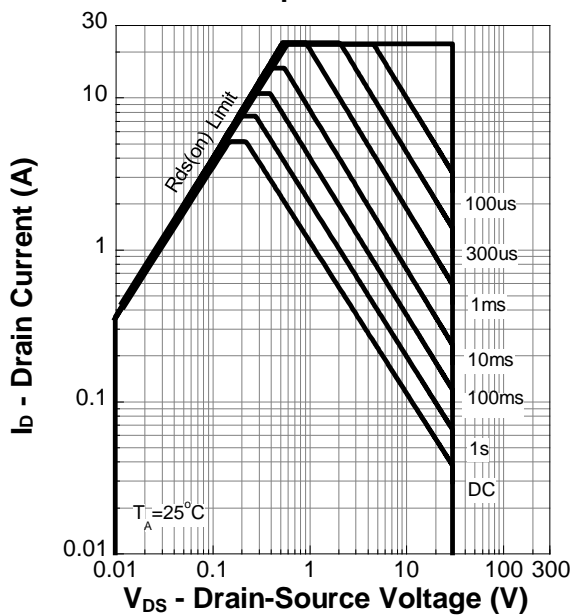

Transient Thermal Impedance

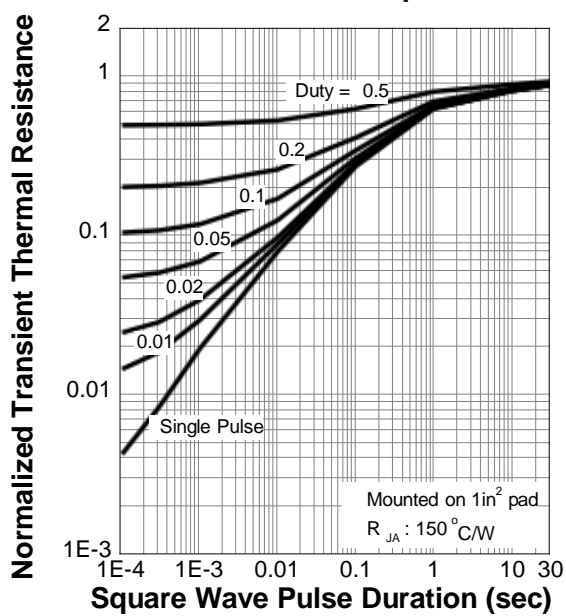

7. Typical Characteristics (Cont.)

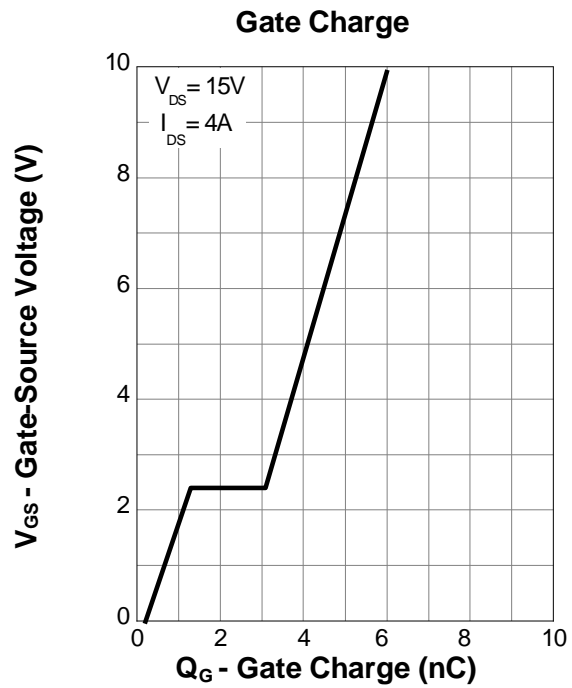
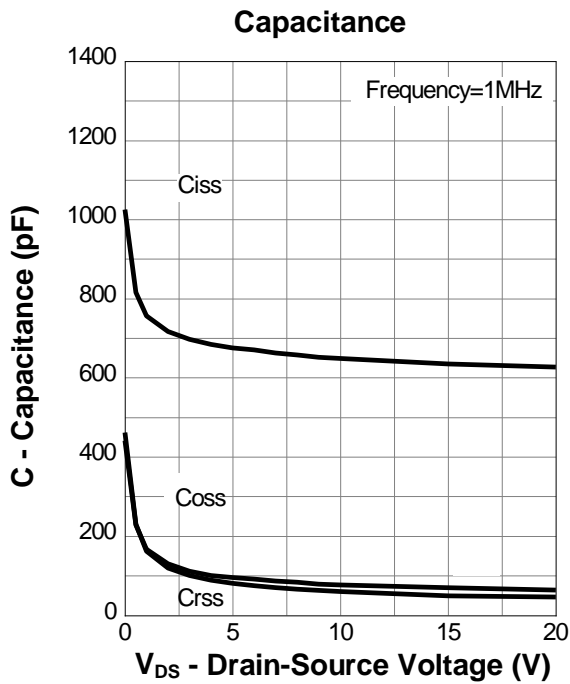
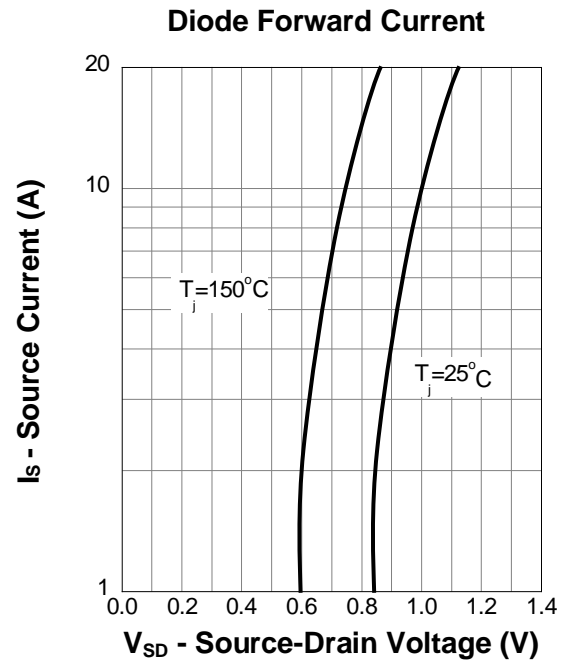
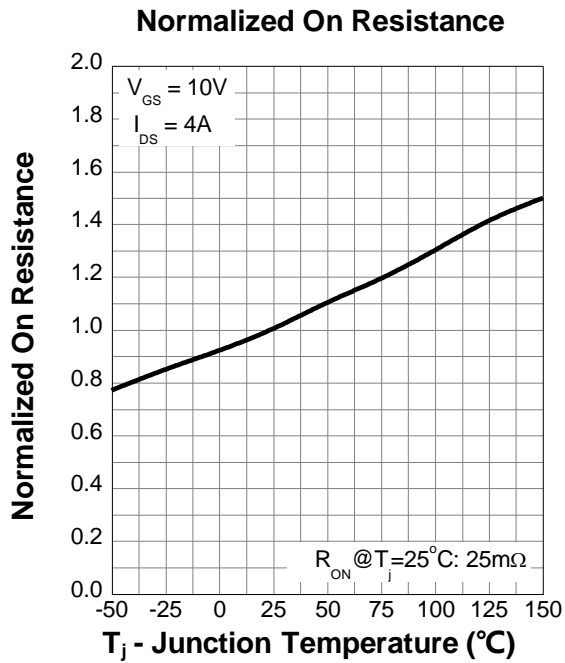

8. Typical Characteristics (Cont.)

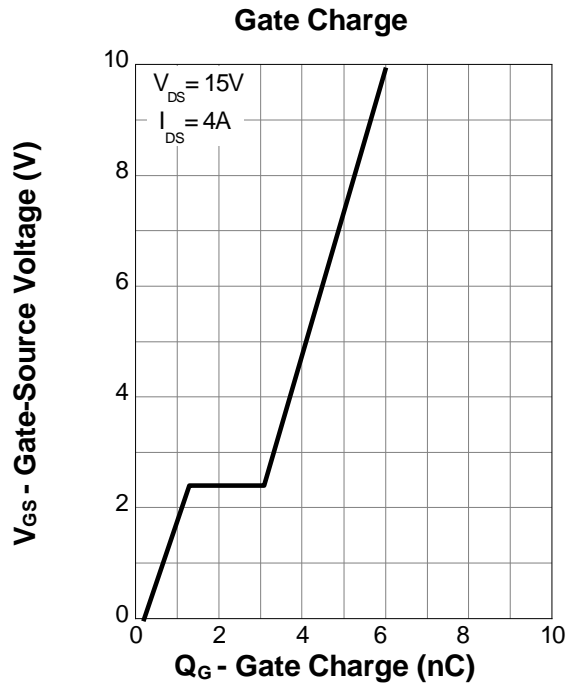
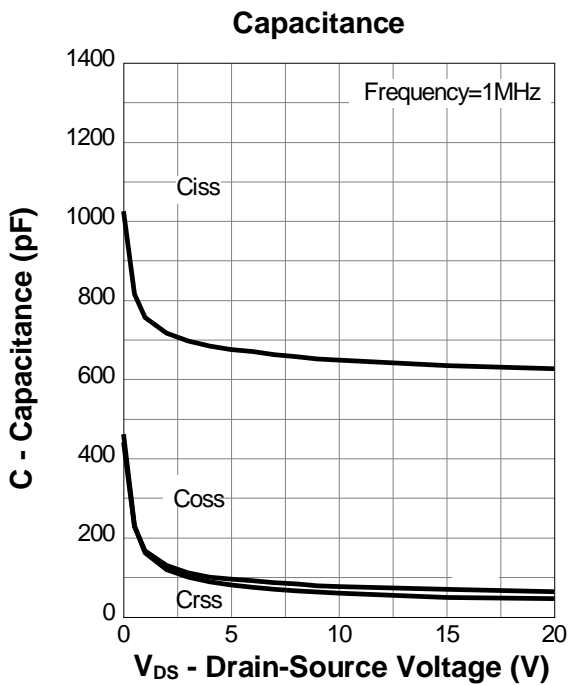
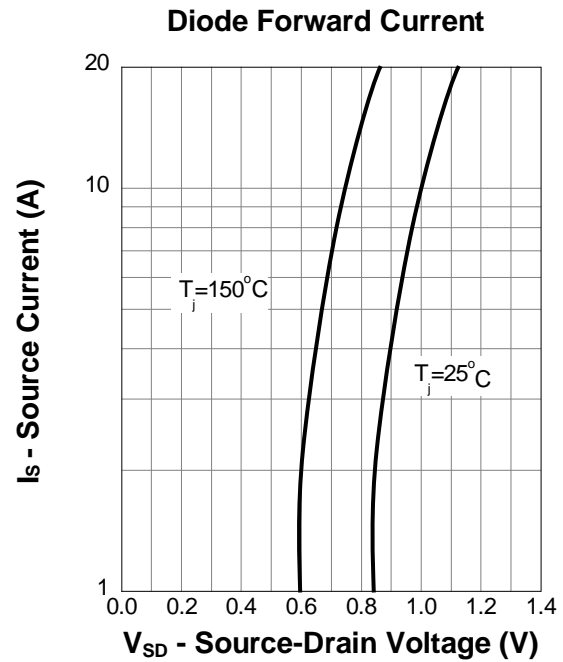
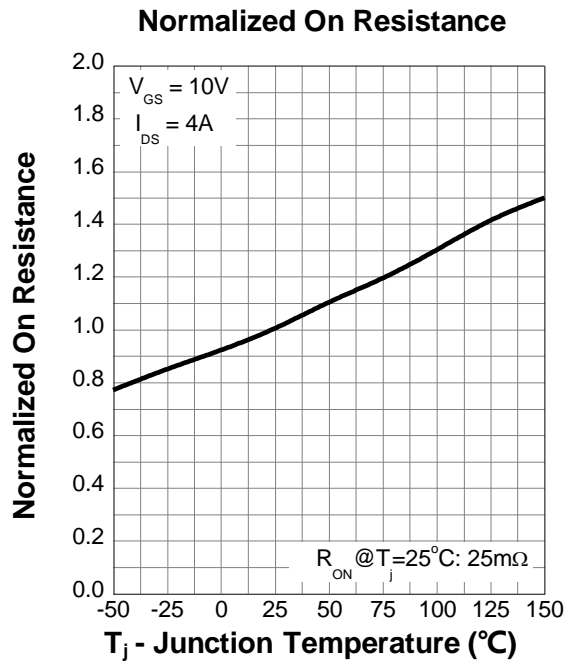

8. Package Dimensions

SOT23 Package

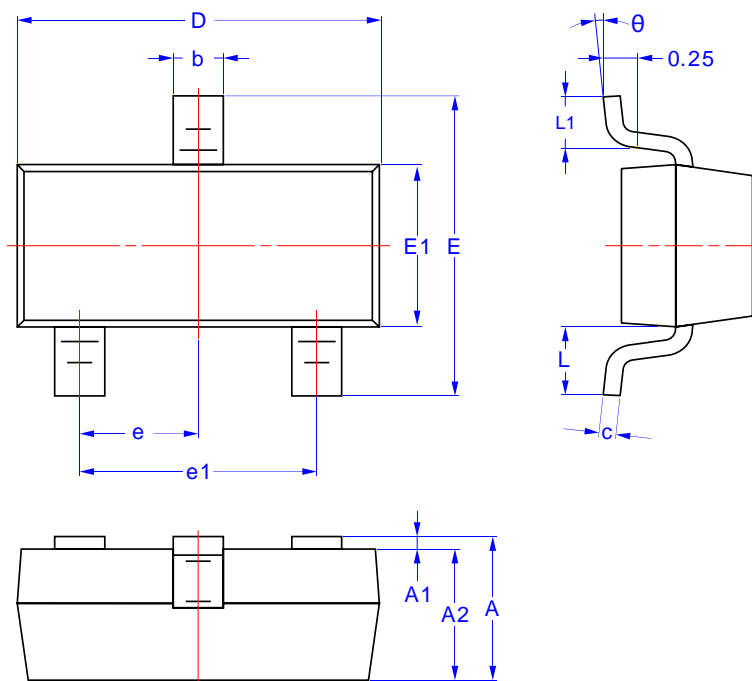

Symbol	Dimensions in Millimeters	
	Min.	Max.
A	0.90	1.15
A1	0.00	0.10
A2	0.90	1.05
b	0.30	0.50
c	0.08	0.15
D	2.80	3.00
E	2.25	2.55
E1	1.20	1.40
e	0.95 TYP.	
e1	1.80	2.00
L	0.30	0.50
L1	0.55 REF.	
θ	0°	8°