

N-Channel Enhancement Mode MOSFET

1. Product Information

1.1 Features

- Surface-mounted package
- Advanced trench cell design
- T_J 175°C
- MSL1

1.2 Applications

- BMS appliances
- High power inverter system
- Drones
- Light electric vehicles

1.3 Quick reference

- BV ≥ 100 V
- R_{DS(ON)} ≤ 2.3 mΩ @V_{GS} = 10 V
- P_D ≤ 286 W
- I_D ≤ 260 A

2. Pin Description

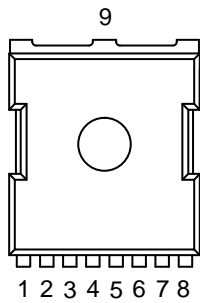
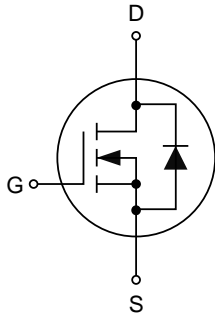
Pin	Description	Simplified Outline	Symbol
1	Gate	 <p style="text-align: center;">Top View TOLL-8L</p>	
2,3,4,5,6,7,8	Source		
9	Drain		

3. Limiting Values

Symbol	Parameter	Conditions	Min	Max	Unit
V_{DS}	Drain-Source Voltage	$T_C=25^{\circ}C$	100	-	V
V_{GS}	Gate-Source Voltage	$T_C=25^{\circ}C$	-	± 20	V
I_D	Drain Current (DC)	$T_C=25^{\circ}C, V_{GS}=10\text{ V}$	-	260	A
		$T_C=100^{\circ}C, V_{GS}=10\text{ V}$	-	178	A
I_{DM}^*	Drain Current (Pulsed)	$T_C=25^{\circ}C, V_{GS}=10\text{ V}$	-	1200	A
P_D	Drain Power Dissipation	$T_C=25^{\circ}C$	-	286	W
I_S	Continuous-Source Current	$T_C=25^{\circ}C$	-	260	A
E_{AS}	Single Pulsed Avalanche Energy	$V_{DD}=40\text{ V}, L=0.1\text{ mH}$	-	1750	mJ
T_J, T_{stg}	Operating Junction and Storage Temperature Range		-55	175	$^{\circ}C$
$R_{\theta JA}^{**}$	Thermal Resistance- Junction to Ambient		-	32.8	$^{\circ}C/W$
$R_{\theta JC}$	Thermal Resistance- Junction to Case		-	0.52	$^{\circ}C/W$

Notes:

- * Pulse width $\leq 300\ \mu s$, duty cycle $\leq 2\%$.
- ** Surface Mounted on minimum footprint pad area.
- *** Limited by bonding wire.

4. Marking Information

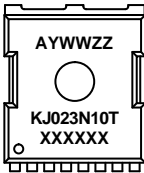
Product Name	Marking
KJ023N10T	

5. Ordering Code

Product Name	Package	Reel Size	Tape width	Quantity (pcs)
KJ023N10T	TOLL-8L	13"	24 mm	2000

Note: KUIJIEYIN defines "Green" as lead-free (RoHS compliant) and halogen free (Br or Cl does not exceed 900 ppm by weight in homogeneous material and total of Br and Cl does not exceed 1500 ppm by weight; Follow IEC 61249-2-21 and IPC/JEDEC J-STD-020C)

6. Electrical Characteristics (T_A=25°C unless otherwise noted)

Symbol	Parameter	Conditions	Min	Typ	Max	Unit
Static Characteristics						
BV _{DSS}	Drain-Source Breakdown Voltage	V _{GS} =0 V, I _{DS} =250 μA	100	-	-	V
V _{GS(th)}	Gate Threshold Voltage	V _{DS} =V _{GS} , I _{DS} =250 μA	2	-	4	V
I _{DSS}	Zero Gate Voltage Source Current	V _{DS} =80 V, V _{GS} =0 V	-	-	1	μA
I _{GSS}	Gate Leakage Current	V _{DS} =0 V, V _{GS} =±20 V	-	-	±100	nA
R _{DS(ON)} ^a	On-State Resistance	V _{GS} =10 V, I _{DS} =20 A	-	2.0	2.3	mΩ
Diode Characteristics						
V _{SD} ^a	Diode Forward Voltage	V _{GS} =0 V, I _{SD} =20 A	-	-	1.3	V
t _{rr}	Reverse Recovery Time	V _{GS} =0 V, I _{SD} =20 A, dI _{SD} /dt=100 A/μs	-	80	-	ns
Q _{rr}	Reverse Recovery Charge		-	195	-	nC
Dynamic Characteristics^b						
C _{iss}	Input Capacitance	V _{DS} =50 V, V _{GS} =0 V, Frequency=1 MHz	-	9200	-	pF
C _{oss}	Output Capacitance		-	1130	-	
C _{rss}	Reverse Transfer Capacitance		-	110	-	
t _{d(on)}	Turn-on Delay Time	V _{DS} =50 V, V _{GEN} =10 V, R _G =4.5 Ω, R _L =2.5 Ω, I _{DS} =20 A	-	32	-	ns
t _r	Turn-on Rise Time		-	40	-	
t _{d(off)}	Turn-off Delay Time		-	80	-	
t _f	Turn-off Fall Time		-	35	-	
Gate Charge Characteristics^b						
Q _g	Total Gate Charge	V _{DS} =50 V, V _{GS} =10 V, I _{DS} =20 A	-	131	-	nC
Q _{gs}	Gate-Source Charge		-	50	-	
Q _{gd}	Gate-Drain Charge		-	23.5	-	

Notes:

- Pulse test; pulse width ≤ 300 μs, duty cycle ≤ 2%.
- Guaranteed by design, not subject to production testing.

7. Typical Characteristics

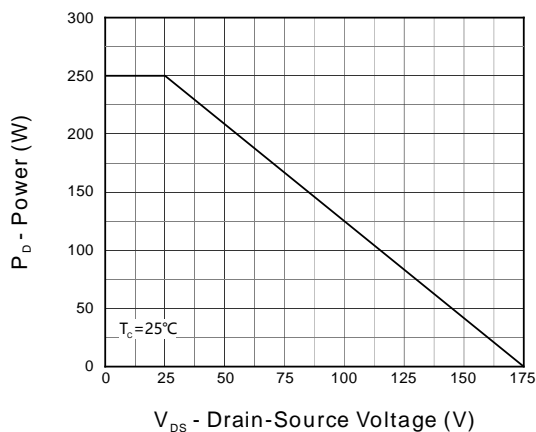

Figure 1. Output Characteristics

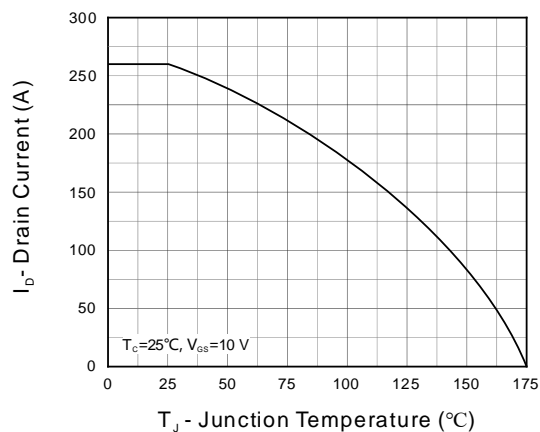

Figure 2. Current Capability

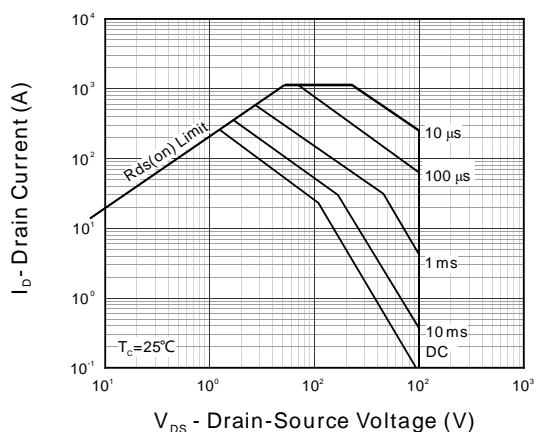

Figure 3. Safe Operation Area

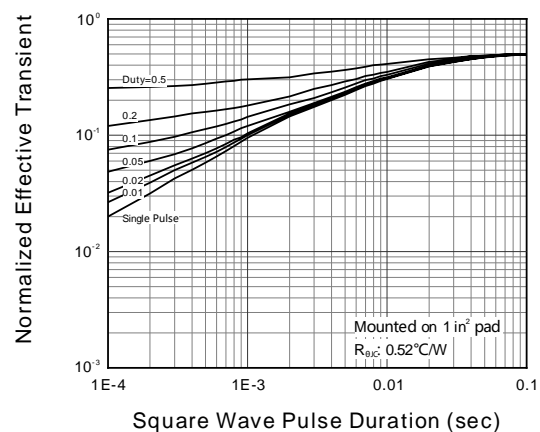

Figure 4. Transient Thermal Impedance

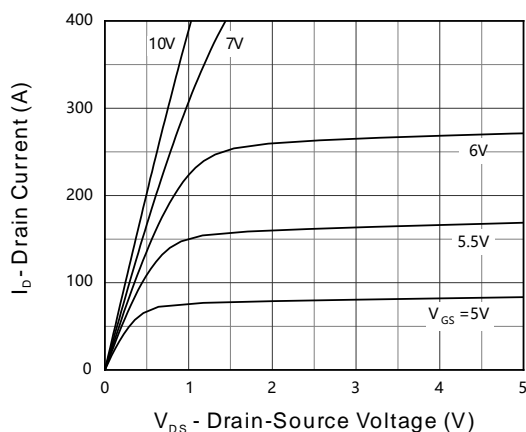

Figure 5. Output Characteristics

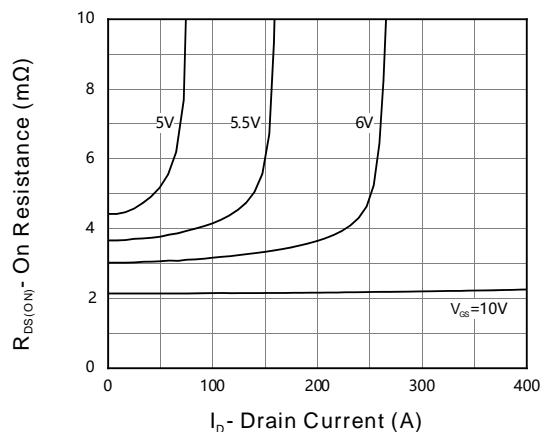

Figure 6. On Resistance

7. Typical Characteristics (cont.)

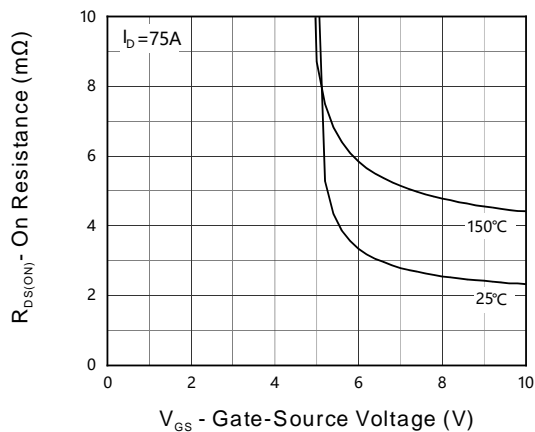

Figure 7. Transfer Characteristics

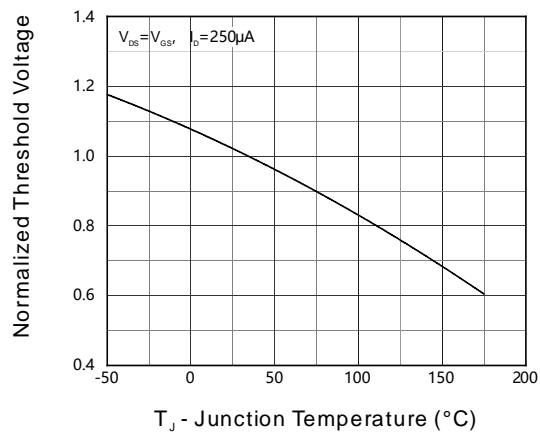

Figure 8. Normalized Threshold Voltage

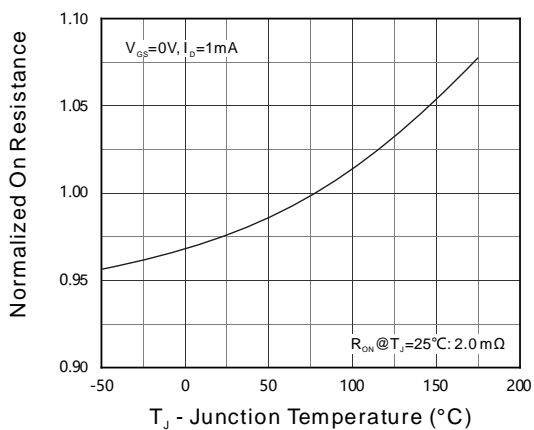

Figure 9. Normalized On Resistance

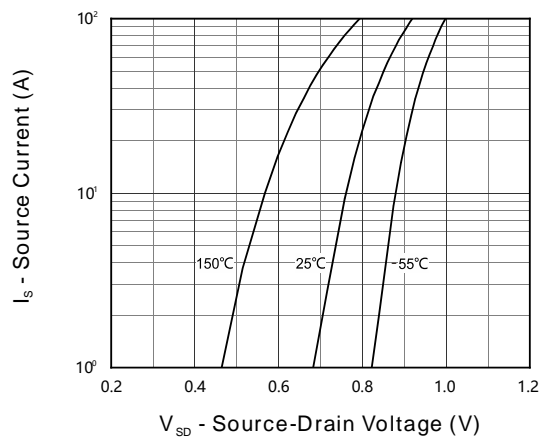

Figure 10. Diode Forward Current

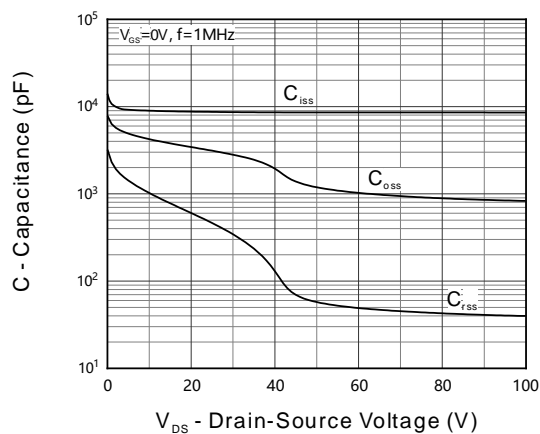

Figure 11. Capacitance

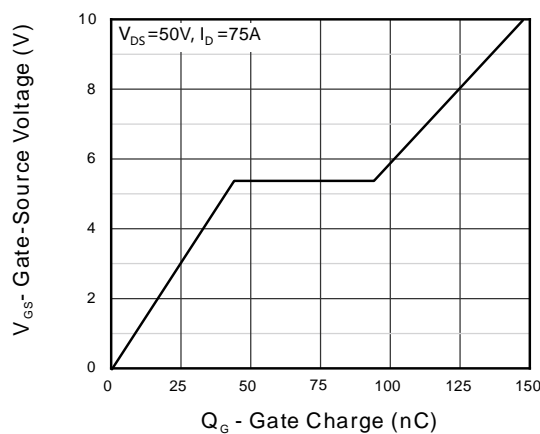
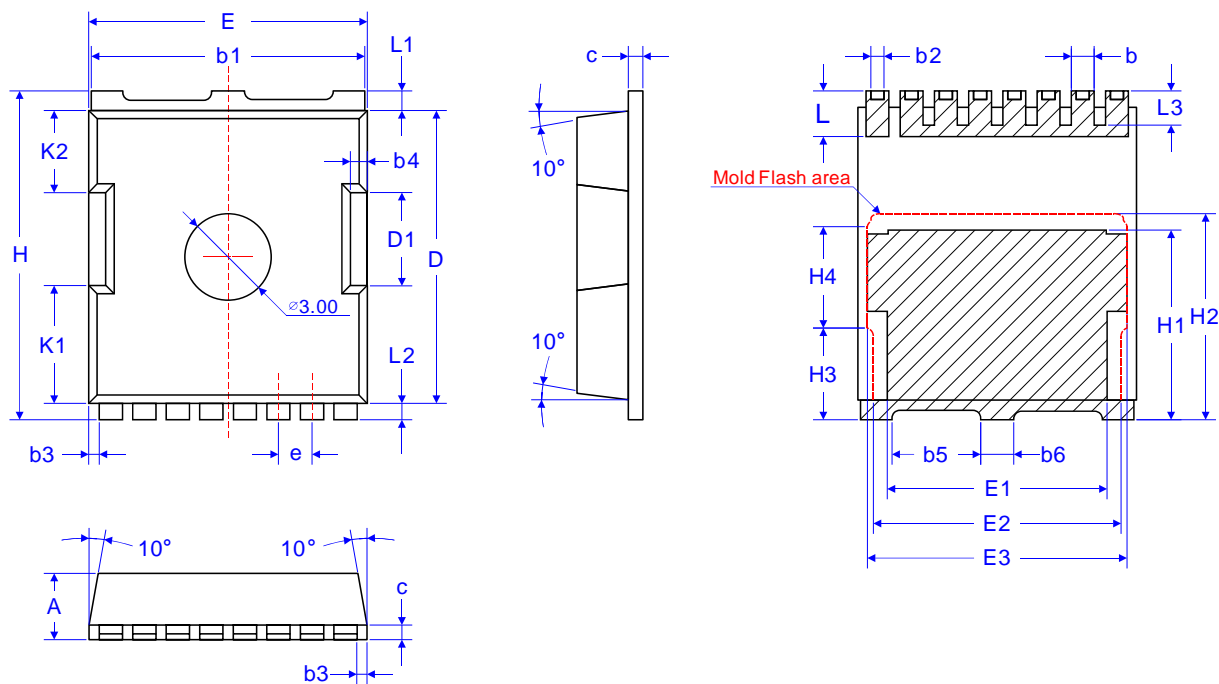

Figure 12. Gate Charge

8. Package Dimensions

TOLL-8L Package



Symbol	Dimensions in Millimeters		
	MIN.	NOM.	MAX.
A	2.20	2.30	2.40
b	0.70	0.80	0.90
b1	9.70	9.80	9.90
b2	0.42	0.46	0.50
b3		0.35	
b4		0.60	
b5		3.10	
b6		1.20	
c	0.492	0.500	0.508
D	10.28	10.38	10.48
D1		3.30	
E	9.80	9.90	10.00
E1		7.80	
E2		8.80	

Symbol	Dimensions in Millimeters		
	MIN.	NOM.	MAX.
E3		9.20	
e		1.20 BSC	
H	11.58	11.68	11.78
H1	6.65	6.75	6.85
H2		7.30	
H3		3.20	
H4		3.80	
K1		4.18	
K2		2.90	
L	1.70	1.90	2.10
L1		0.70	
L2		0.60	
L3	1.05	1.15	1.25