

## N-Channel Enhancement Mode MOSFET

### 1. Product Information

#### 1.1 Features

- Surface-mounted package
- Advanced trench cell design

#### 1.2 Applications

- LCD TV appliances
- High power inverter system
- LCDM appliances

#### 1.3 Quick reference

- $BV \geq 120\text{ V}$
- $R_{DS(ON)} \leq 3.0\text{ m}\Omega @ V_{GS} = 10\text{ V}$
- $P_{tot} \leq 300\text{ W}$
- $R_{DS(ON)} \leq 4.0\text{ m}\Omega @ V_{GS} = 6\text{ V}$
- $I_D \leq 188\text{ A}$

### 2. Pin Description

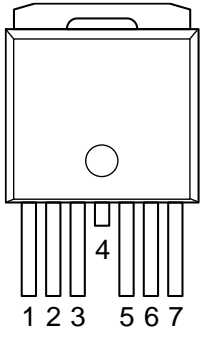
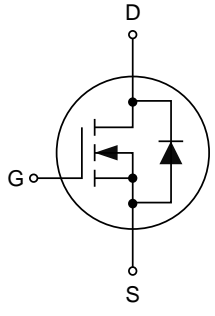
Pin	Description	Simplified Outline	Symbol
1	Gate(G)	 <p>Top View TO263-7L</p>	
2, 3	Source(S)		
4	Drain(D)		
5, 6, 7	Source(S)		

## 3. Limiting Values

Symbol	Parameter	Conditions	Min	Max	Unit
V <sub>DS</sub>	Drain-Source Voltage	T <sub>C</sub> =25°C	-	120	V
V <sub>GS</sub>	Gate-Source Voltage	T <sub>C</sub> =25°C	-	±20	V
I <sub>D</sub> <sup>*,***</sup>	Drain Current (DC)	T <sub>C</sub> =25°C, V <sub>GS</sub> =10 V	-	188	A
I <sub>DM</sub> <sup>**</sup>	Drain Current (Pulsed)	T <sub>C</sub> =25°C, V <sub>GS</sub> =10 V	-	750	A
P <sub>tot</sub>	Drain Power Dissipation	T <sub>C</sub> =25°C	-	300	W
T <sub>J</sub> , T <sub>stg</sub>	Operating Junction and Storage Temperature		-55	175	°C
I <sub>S</sub>	Continuous-Source Current	T <sub>C</sub> =25°C	-	188	A
E <sub>AS</sub> <sup>*</sup>	Single Pulsed Avalanche Energy	V <sub>DD</sub> =40 V, L=0.1 mH	-	1625	mJ
R <sub>θJA</sub> <sup>*</sup>	Thermal Resistance-Junction to Ambient		-	40	°C/W
R <sub>θJC</sub> <sup>*</sup>	Thermal Resistance-Junction to Case		-	0.5	°C/W

Notes:

- \* Surface Mounted on 1 in<sup>2</sup> pad area, t ≤ 10 sec
- \*\* Pulse width ≤ 300 μs, duty cycle ≤ 2%
- \*\*\* Limited by bonding wire

## 4. Marking Information

Product Name	Marking
KJ03N12D7	<div style="background-color: black; color: white; padding: 5px; text-align: center;"> <b>KJ03N12D7</b>  <b>AYWWXX</b>  <b>XXXXXX</b> </div>

## 5. Ordering Code

Product Name	Package	Reel Size	Tape width	Quantity	Note
KJ03N12D7	TO263-7L	-	-	800	

Note: KUAJIEXIN defines "Green" as lead-free (RoHS compliant) and halogen free (Br or Cl does not exceed 900 ppm by weight in homogeneous material and total of Br and Cl does not exceed 1500 ppm by weight; Follow IEC 61249-2-21 and IPC/JEDEC J-STD-020C)

## 6. Electrical Characteristics (T<sub>A</sub>=25°C Unless Otherwise Noted)

Symbol	Parameter	Conditions	Min	Typ	Max	Unit
<b>Static Characteristics</b>						
BV <sub>DSS</sub>	Drain-Source Breakdown Voltage	V <sub>GS</sub> =0 V, I <sub>DS</sub> =250 μA	120	-	-	V
V <sub>GS(th)</sub>	Gate Threshold Voltage	V <sub>DS</sub> =V <sub>GS</sub> , I <sub>DS</sub> =25 0μA	2.0	-	4.0	V
I <sub>DSS</sub>	Drain Leakage Current	V <sub>DS</sub> =96 V, V <sub>GS</sub> =0 V	-	-	1	μA
I <sub>GSS</sub>	Gate Leakage Current	V <sub>GS</sub> =±20 V, V <sub>DS</sub> =0 V	-	-	±100	nA
R <sub>DS(ON)</sub> <sup>a</sup>	On-State Resistance	V <sub>GS</sub> =10 V, I <sub>DS</sub> =50 A	-	2.7	3.0	mΩ
		V <sub>GS</sub> =6 V, I <sub>DS</sub> =30 A	-	3.4	4.0	mΩ
<b>Diode Characteristics</b>						
V <sub>SD</sub> <sup>a</sup>	Diode Forward Voltage	I <sub>SD</sub> =50 A, V <sub>GS</sub> =0 V	-	-	1.3	V
t <sub>rr</sub>	Reverse Recovery Time	I <sub>SD</sub> =50 A, V <sub>GS</sub> =0 V, dI <sub>SD</sub> /dt=100 A/μs	-	123	-	ns
Q <sub>rr</sub>	Reverse Recovery Charge		-	396	-	nC
<b>Dynamic Characteristics<sup>b</sup></b>						
C <sub>iss</sub>	Input Capacitance	V <sub>GS</sub> =0 V, V <sub>DS</sub> =60 V, Frequency=1 MHz	-	9161	-	pF
C <sub>oss</sub>	Output Capacitance		-	1034	-	
C <sub>rss</sub>	Reverse Transfer Capacitance		-	56	-	
t <sub>d(on)</sub>	Turn-on Delay Time	V <sub>DS</sub> =60 V, V <sub>GEN</sub> =10 V, R <sub>G</sub> =3.9 Ω, R <sub>L</sub> =1.2 Ω, I <sub>DS</sub> =50 A	-	28	-	ns
t <sub>r</sub>	Turn-on Rise Time		-	96	-	
t <sub>d(off)</sub>	Turn-off Delay Time		-	101	-	
t <sub>f</sub>	Turn-off Fall Time		-	90	-	
<b>Gate Charge Characteristics<sup>b</sup></b>						
Q <sub>g</sub>	Total Gate Charge	V <sub>DS</sub> =60 V, V <sub>GS</sub> =10 V, I <sub>DS</sub> =50 A	-	157	-	nC
Q <sub>gs</sub>	Gate-Source Charge		-	50	-	
Q <sub>gd</sub>	Gate-Drain Charge		-	38	-	

Notes:

- Pulse test; pulse width ≤ 300 μs, duty cycle ≤ 2%
- Guaranteed by design, not subject to production testing

## 7. Typical Characteristics

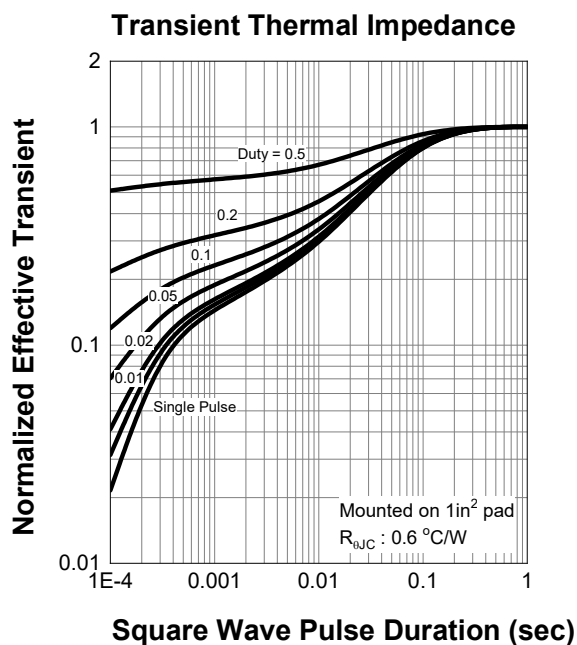
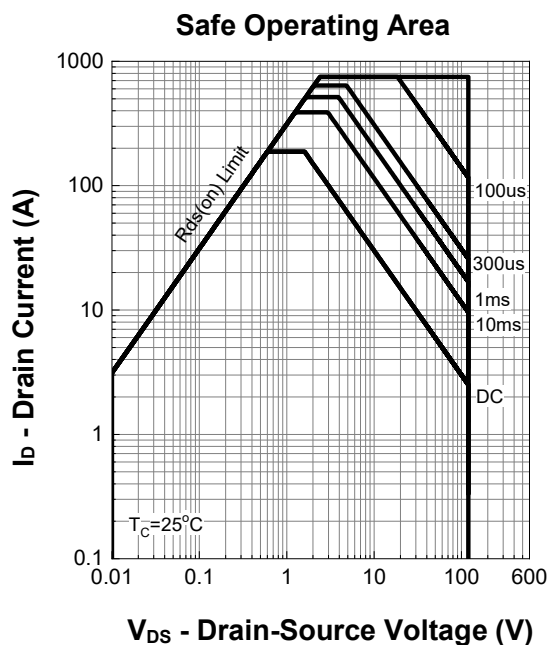
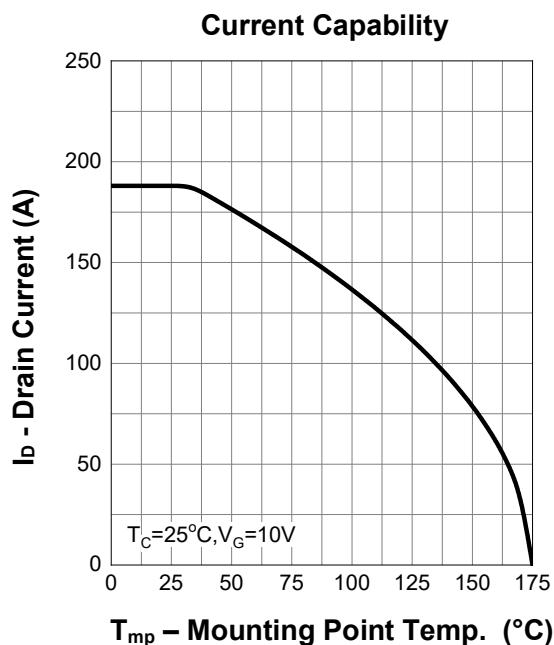
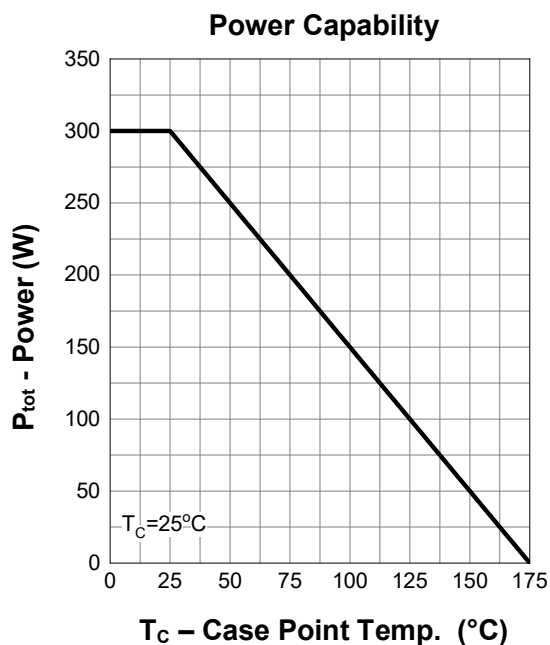

## 7. Typical Characteristics (cont.)

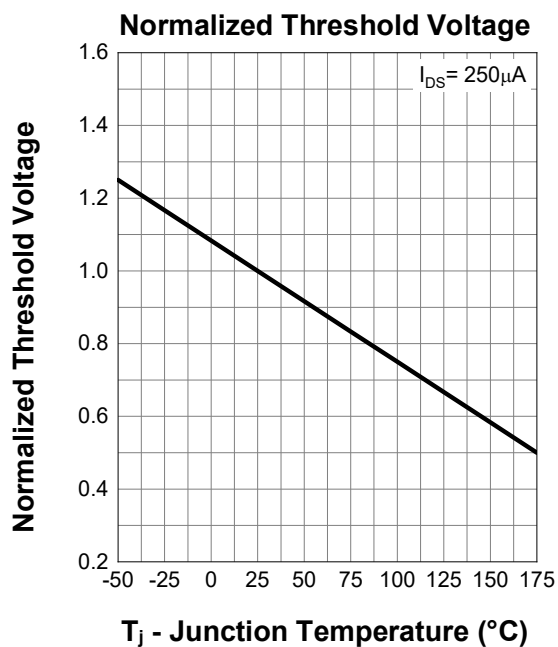
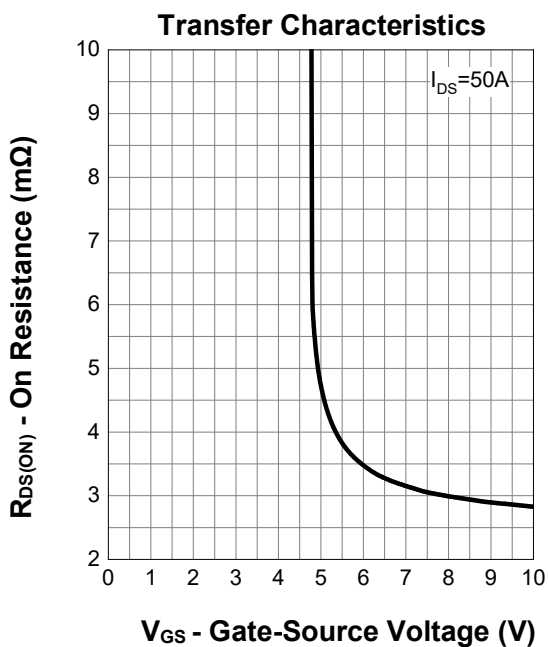
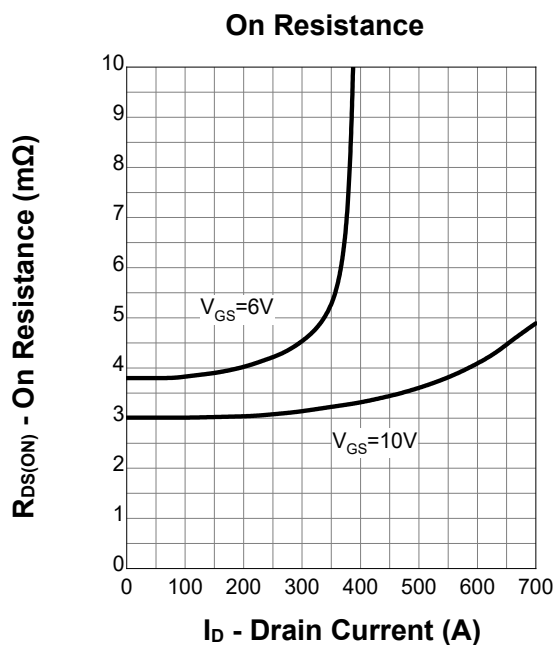
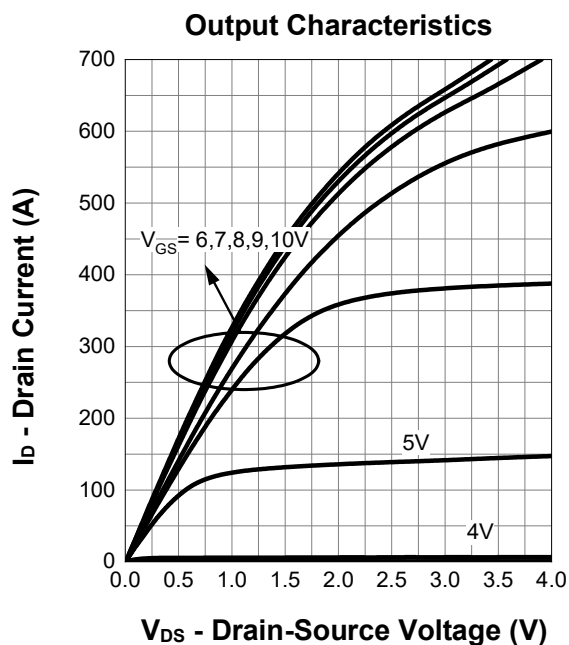

## 7. Typical Characteristics (cont.)

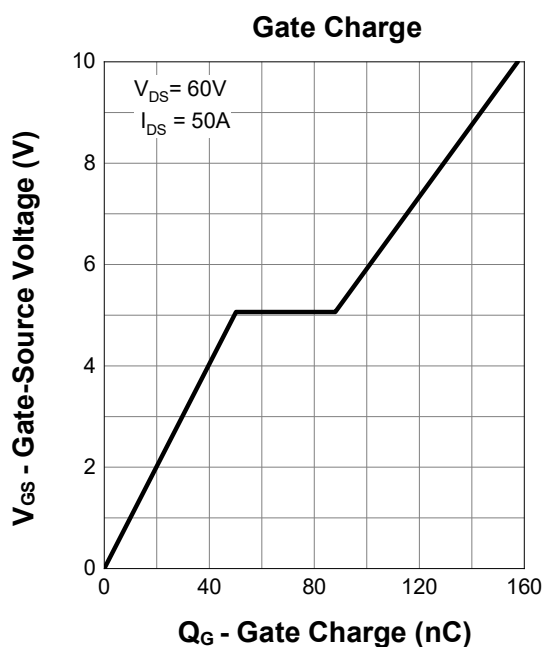
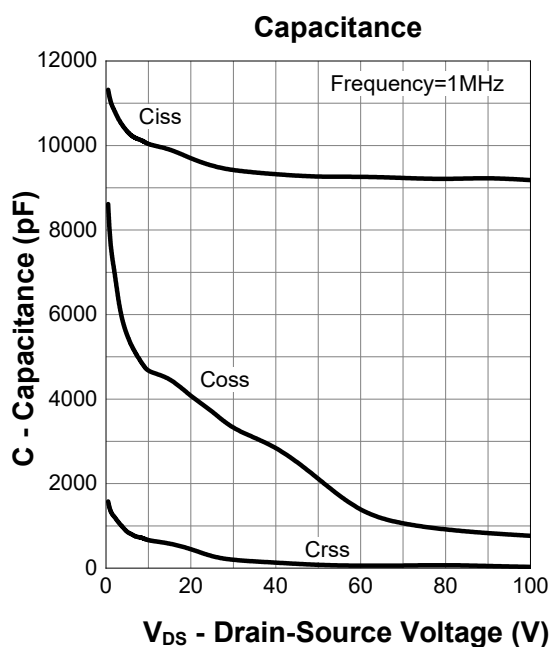
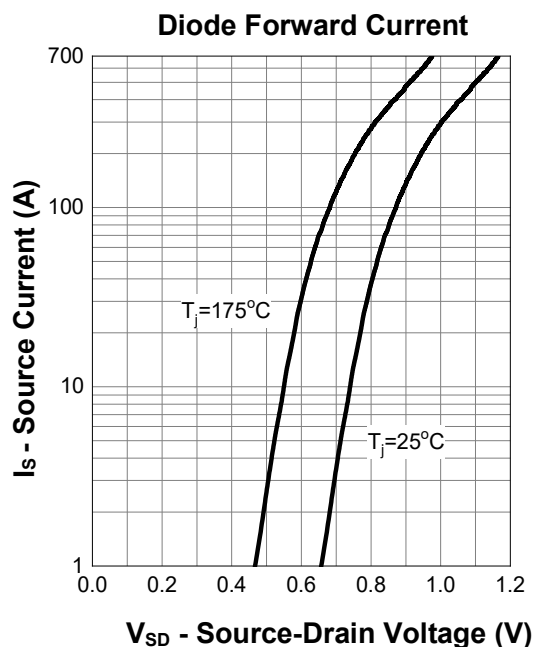
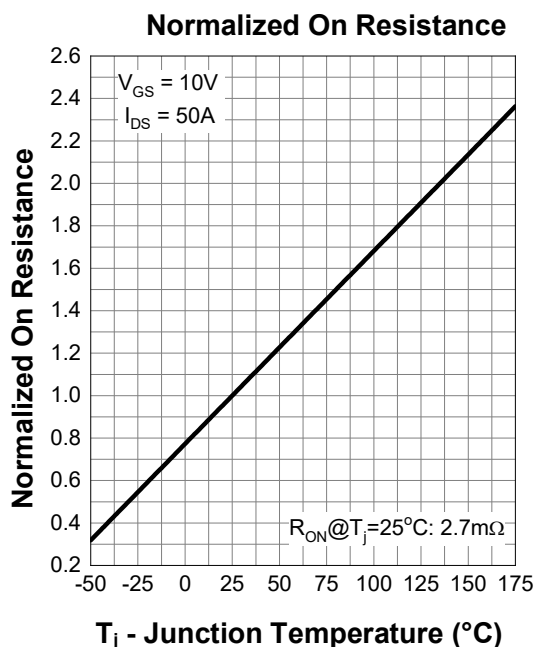

## 8. Package Dimensions

### TO263-7L Package

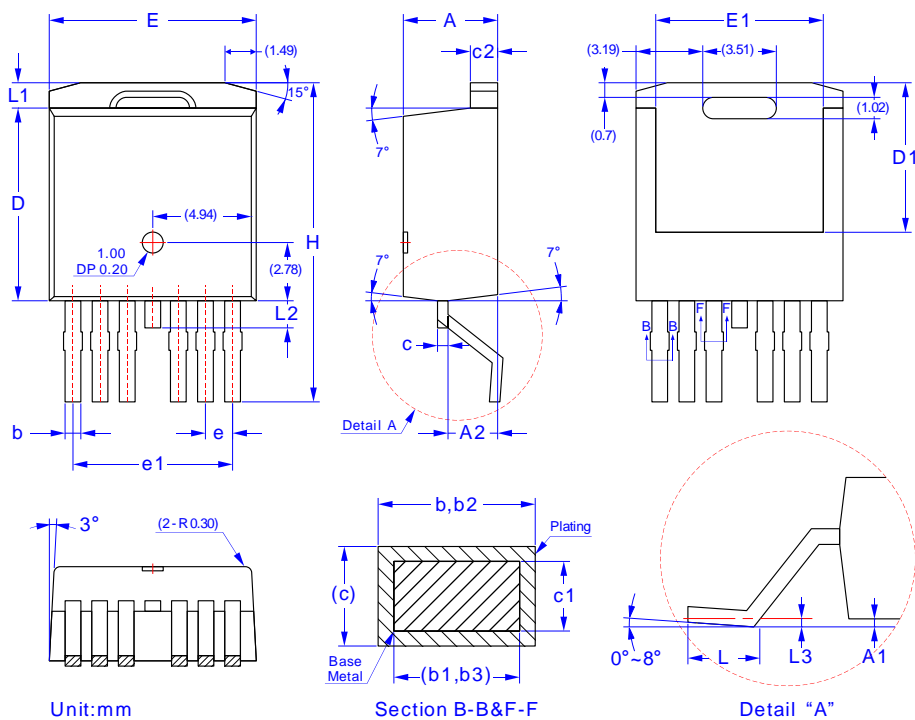

Symbol	Dimensions in Millimeters	
	MIN.	MAX.
A	4.30	4.70
A1	-	0.25
A2	2.20	2.60
b	0.65	0.85
b1	0.65	0.80
b2	0.80	1.00
b3	0.80	0.95
c	0.45	0.60
c1	0.45	0.55
c2	1.25	1.40
D	9.00	9.40
D1	6.86	7.42
E	9.68	10.08
E1	7.70	8.30
e	1.27 BSC	
e1	7.62 BSC	
L	1.78	2.79
L1	-	1.60
L2	-	1.78
L3	0.25 BSC	
H	14.61	15.88