

N-Channel Enhancement Mode MOSFET

1. Product Information

1.1 Features

- Surface-mounted package
- Advanced trench cell design
- Super Trench
- MSL1
- T_J max 175°C

1.2 Applications

- Power appliances
- High power inverter system
- E- Tool appliances
- BMS

1.3 Quick reference

- BV ≥ 40 V
- R_{DS(ON)} ≤ 1.0 mΩ @V_{GS} = 10 V
- P_D ≤ 300 W
- R_{DS(ON)} ≤ 1.3 mΩ @V_{GS} = 4.5 V
- I_D ≤ 400 A

2. Pin Description

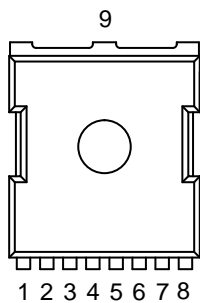
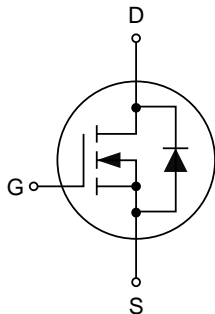
Pin	Description	Simplified Outline	Symbol
1	Gate	 <p style="text-align: center;">9</p> <p style="text-align: center;">1 2 3 4 5 6 7 8</p> <p style="text-align: center;">Top View TOLL-8L</p>	
2,3,4,5,6,7,8	Source		
9	Drain		

3. Limiting Values

Symbol	Parameter	Conditions	Min	Max	Unit
V_{DS}	Drain-Source Voltage	$T_C=25^{\circ}C$	40	-	V
V_{GS}	Gate-Source Voltage	$T_C=25^{\circ}C$	-	± 20	V
$I_D^{*,***}$	Drain Current (DC)	$T_C=25^{\circ}C, V_{GS}=10\text{ V}$	-	400	A
		$T_C=100^{\circ}C, V_{GS}=10\text{ V}$	-	275	A
$I_{DM}^{**,***}$	Drain Current (Pulsed)	$T_C=25^{\circ}C, V_{GS}=10\text{ V}$	-	1600	A
P_{tot}	Drain Power Dissipation	$T_C=25^{\circ}C$	-	300	W
I_S	Continuous-Source Current	$T_C=25^{\circ}C$	-	400	A
E_{AS}	Single Pulsed Avalanche Energy	$V_{DD}=40\text{ V}, L=1.0\text{ mH}$	-	1352	mJ
T_J, T_{stg}	Operating Junction and Storage Temperature Range		-55	175	$^{\circ}C$
$R_{\theta JA}^{**}$	Thermal Resistance-Junction to Ambient		-	32.8	$^{\circ}C/W$
$R_{\theta JC}^{**}$	Thermal Resistance-Junction to Case		-	0.5	$^{\circ}C/W$

Notes:

- * Surface mounted on minimum footprint pad area.
- ** Pulse width $\leq 300\ \mu s$, duty cycle $\leq 2\%$.
- *** Maximum current rating is package limited.

4. Marking Information

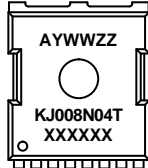
Product Name	Marking
KJ008N04T	

5. Ordering Code

Product Name	Package	Reel Size	Tape width	Quantity (pcs)
KJ008N04T	TOLL-8L	13"	24 mm	2000

Note: KUIJIEXIN defines "Green" as lead-free (RoHS compliant) and halogen free (Br or Cl does not exceed 900 ppm by weight in homogeneous material and total of Br and Cl does not exceed 1500 ppm by weight; Follow IEC 61249-2-21 and IPC/JEDEC J-STD-020C)

6. Electrical Characteristics (T_A=25°C unless otherwise noted)

Symbol	Parameter	Conditions	Min	Typ	Max	Unit
Static Characteristics						
BV _{DSS}	Drain-Source Breakdown Voltage	V _{GS} =0 V, I _{DS} =250 μA	40	-	-	V
V _{GS(th)}	Gate Threshold Voltage	V _{DS} =V _{GS} , I _{DS} =250 μA	1	-	2	V
I _{DSS}	Drain Leakage Current	V _{DS} =32 V, V _{GS} =0 V	-	-	1	μA
I _{GSS}	Gate Leakage Current	V _{DS} =0 V, V _{GS} =±20 V	-	-	±100	nA
R _{DS(ON)} ^a	On-State Resistance	V _{GS} =10 V, I _{DS} =50 A	-	0.85	1	mΩ
		V _{GS} =4.5 V, I _{DS} =20 A	-	1.1	1.3	mΩ
Diode Characteristics						
V _{SD} ^a	Diode Forward Voltage	V _{GS} =0 V, I _{SD} =50 A	-	-	1.3	V
t _{rr}	Reverse Recovery Time	V _{GS} =0 V, I _{DS} =50 A, dI _{SD} /dt=100 A/μs	-	97	-	ns
Q _{rr}	Reverse Recovery Charge		-	162	-	nC
Dynamic Characteristics^b						
C _{iss}	Input Capacitance	V _{DS} =20 V, V _{GS} =0 V, Frequency=1 MHz	-	8296	-	pF
C _{oss}	Output Capacitance		-	3294	-	
C _{rss}	Reverse Transfer Capacitance		-	55	-	
t _{d(on)}	Turn-on Delay Time	V _{DS} =20 V, V _{GEN} =10 V, R _G =4.5 Ω, R _L =0.4 Ω, I _{DS} =50 A	-	19	-	ns
t _r	Turn-on Rise Time		-	84	-	
t _{d(off)}	Turn-off Delay Time		-	153	-	
t _f	Turn-off Fall Time		-	126	-	
Gate Charge Characteristics^b						
Q _g	Total Gate Charge	V _{DS} =20 V, V _{GS} =10 V, I _{DS} =50 A	-	148	-	nC
Q _{gs}	Gate-Source Charge		-	26	-	
Q _{gd}	Gate-Drain Charge		-	25	-	

Notes:

- Pulse test; pulse width ≤ 300 μs, duty cycle ≤ 2%.
- Guaranteed by design, not subject to production testing.

7. Typical Characteristics

Power Capability

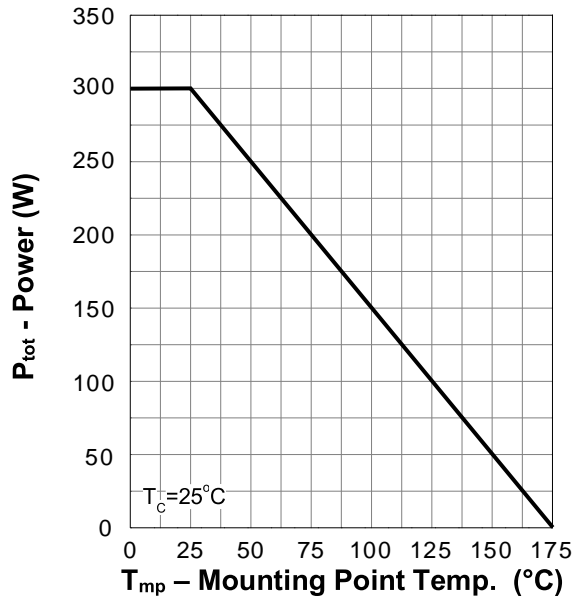

Current Capability

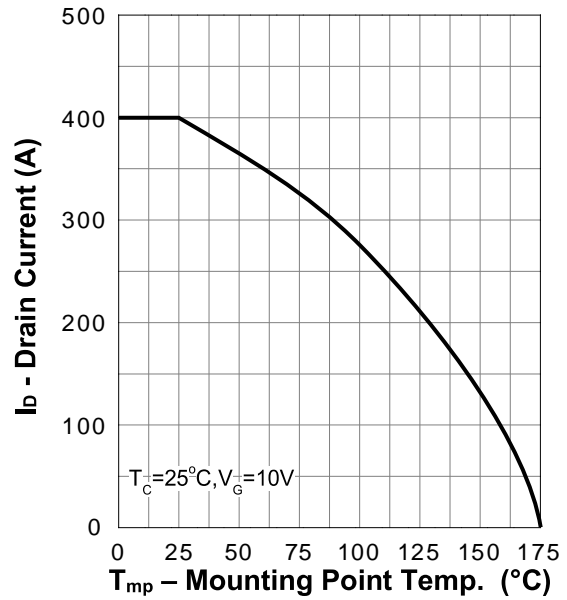

Safe Operating Area

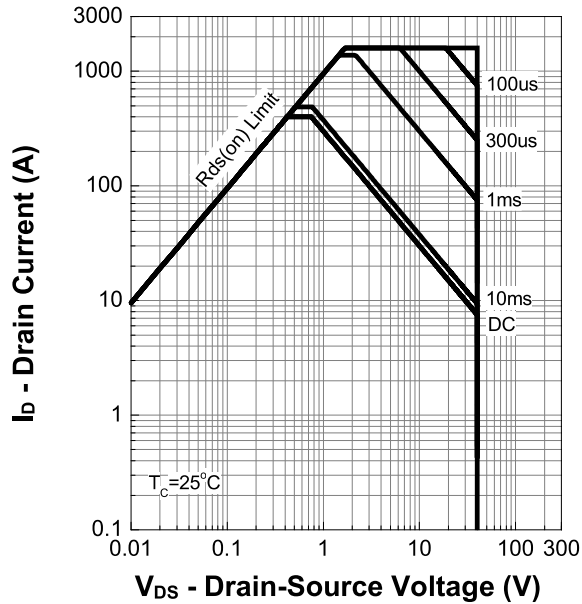

Transient Thermal Impedance

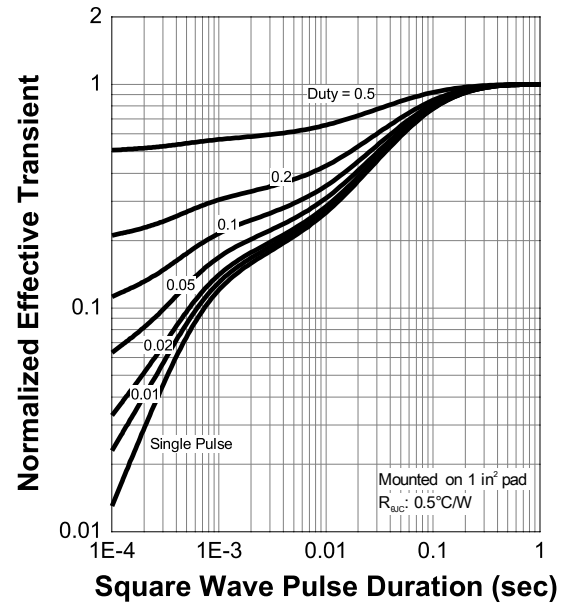

7. Typical Characteristics (cont.)

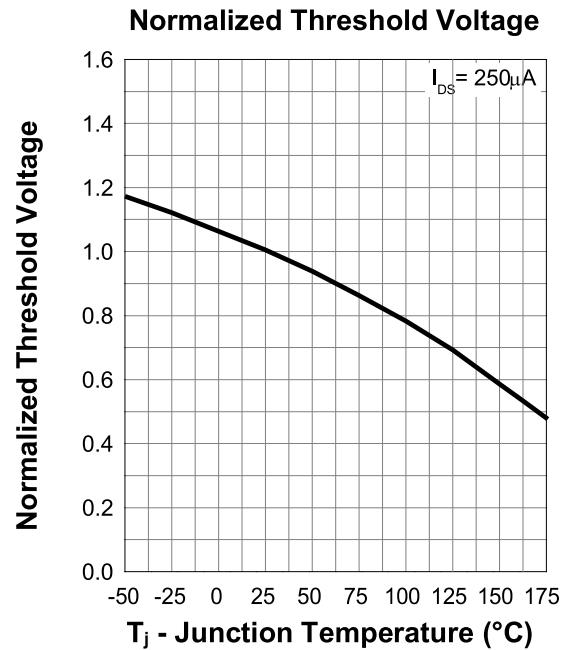
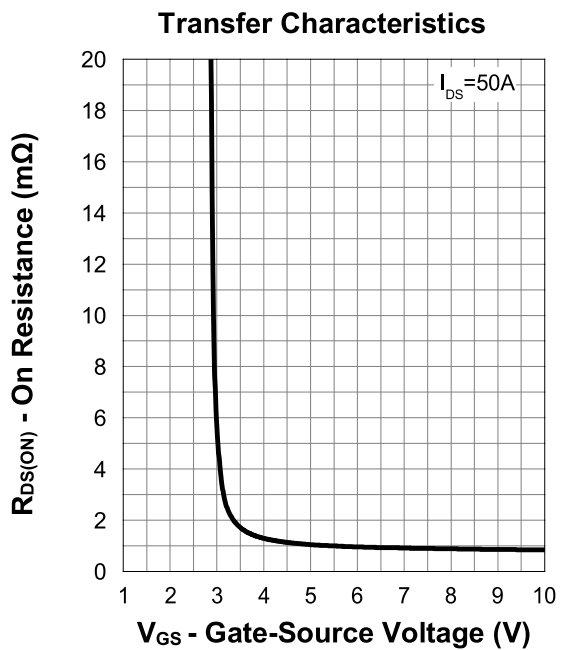
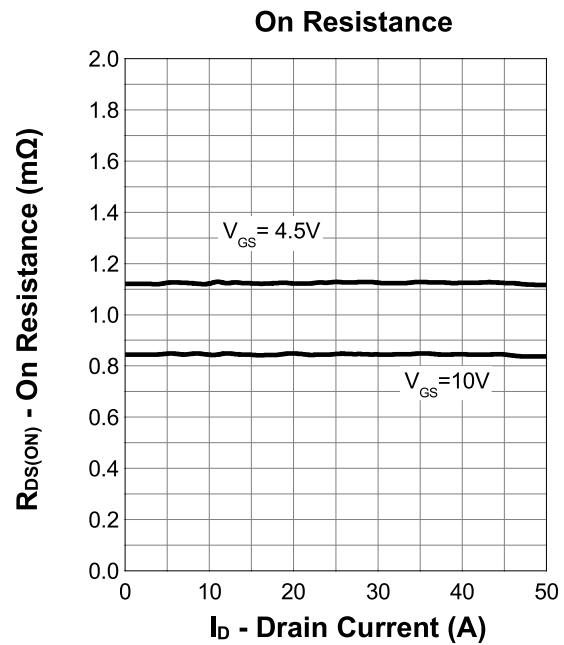
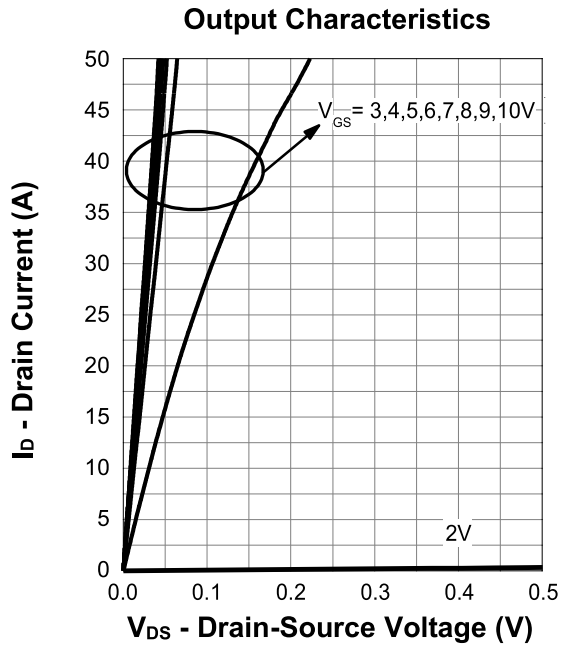

7. Typical Characteristics (cont.)

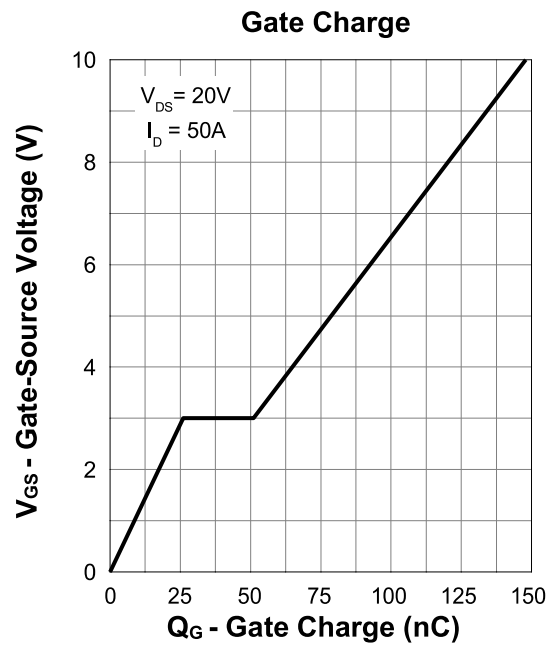
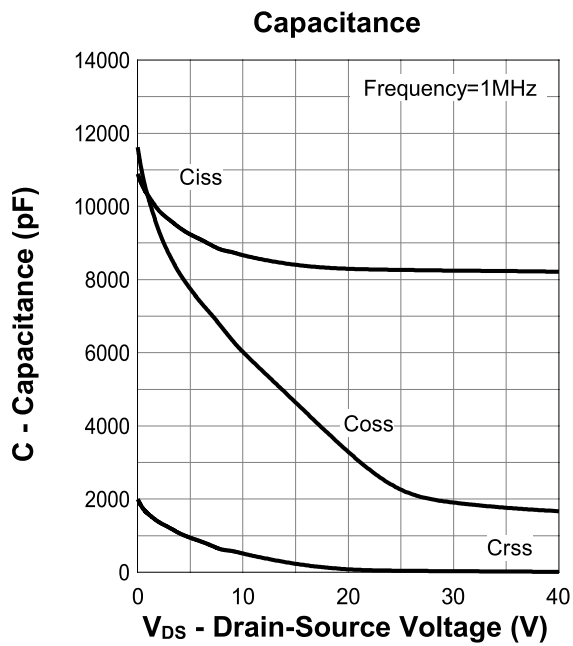
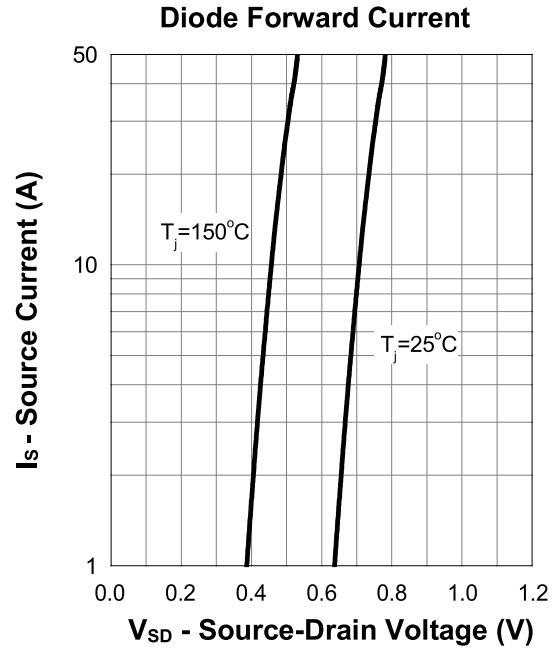
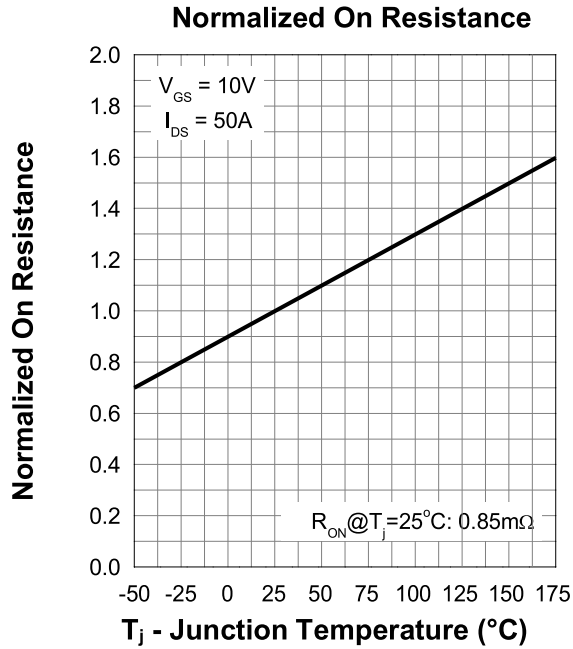

8. Package Dimensions

TOLL-8L Package

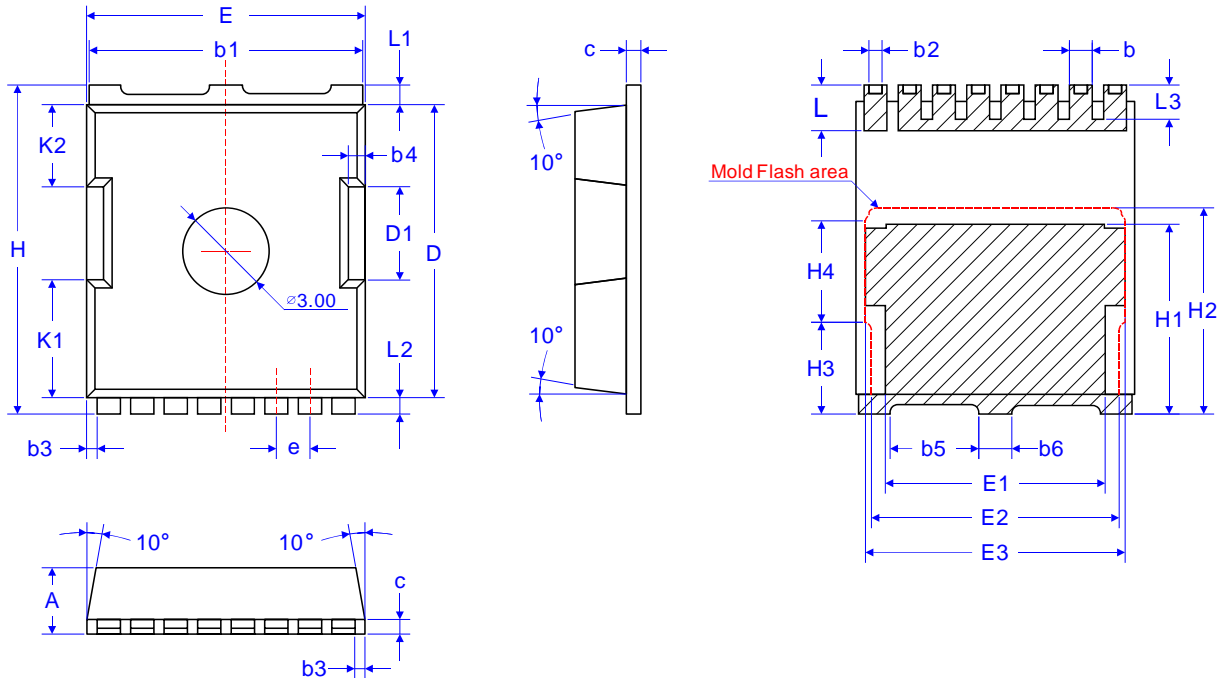

Symbol	Dimensions in Millimeters		
	MIN	NOM	MAX
A	2.20	2.30	2.40
b	0.70	0.80	0.90
b1	9.70	9.80	9.90
b2	0.42	0.46	0.50
b3		0.35	
b4		0.60	
b5		3.10	
b6		1.20	
c	0.492	0.500	0.508
D	10.28	10.38	10.48
D1		3.30	
E	9.80	9.90	10.00
E1		7.80	
E2		8.80	

Symbol	Dimensions in Millimeters		
	MIN	NOM	MAX
E3		9.20	
e		1.20 BSC	
H	11.58	11.68	11.78
H1	6.65	6.75	6.85
H2		7.30	
H3		3.20	
H4		3.80	
K1		4.18	
K2		2.90	
L	1.70	1.90	2.10
L1		0.70	
L2		0.60	
L3	1.05	1.15	1.25