

N-Channel Enhancement Mode MOSFET

1. Product Information

1.1 Features

- Surface-mounted package
- Super Trench
- T_J max 175°C
- Advanced trench cell design
- MSL1

1.2 Applications

- BMS appliances
- Drones
- High power inverter system
- Light electric vehicles

1.3 Quick reference

- BV ≥ 100 V
- P_D ≤ 500 W
- I_D ≤ 400 A
- R_{DS(ON)} ≤ 1.25 mΩ @V_{GS} = 10 V
- R_{DS(ON)} ≤ 1.85 mΩ @V_{GS} = 6 V

2. Pin Description

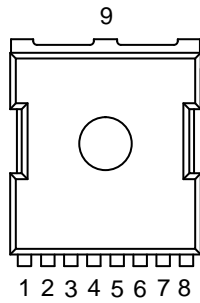
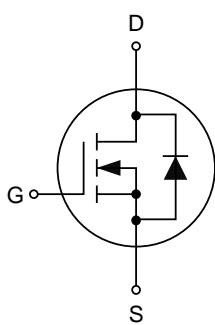
Pin	Description	Simplified Outline	Symbol
1	Gate	 <p style="text-align: center;">Top View TOLL-8L</p>	
2,3,4,5,6,7,8	Source		
9	Drain		

3. Limiting Values

Symbol	Parameter	Conditions	Min	Max	Unit
V _{DS}	Drain-Source Voltage	T _C =25°C	100	-	V
V _{GS}	Gate-Source Voltage	T _C =25°C	-	±20	V
I _D *	Drain Current (DC)	T _C =25°C, V _{GS} =10 V	-	400	A
		T _C =100°C, V _{GS} =10 V	-	280	A
I _{DM} *, **	Drain Current (Pulsed)	T _C =25°C, V _{GS} =10 V	-	1400	A
P _D	Drain Power Dissipation	T _C =25°C	-	500	W
I _S	Continuous-Source Current	T _C =25°C	-	400	A
E _{AS}	Single Pulsed Avalanche Energy	V _{DD} =50 V, L=1.0 mH	-	2800	mJ
T _J , T _{stg}	Operating Junction and Storage Temperature Range		-55	175	°C
R _{θJA} **	Thermal Resistance-Junction to Ambient		-	40	°C/W
R _{θJC} **	Thermal Resistance-Junction to Case		-	0.3	°C/W

Notes:

- * Pulse width ≤ 300 μs, duty cycle ≤ 2%.
- ** Surface mounted on minimum footprint pad area.
- *** Limited by bonding wire.

4. Marking Information

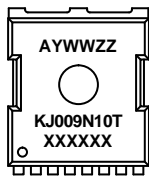
Product Name	Marking
KJ009N10T	

5. Ordering Code

Product Name	Package	Reel Size	Tape width	Quantity (pcs)
KJ009N10T	TOLL-8L	13"	24 mm	2000

Note: KUIJIEXIN defines "Green" as lead-free (RoHS compliant) and halogen free (Br or Cl does not exceed 900 ppm by weight in homogeneous material and total of Br and Cl does not exceed 1500 ppm by weight; Follow IEC 61249-2-21 and IPC/JEDEC J-STD-020C)

6. Electrical Characteristics (T_A=25°C unless otherwise noted)

Symbol	Parameter	Conditions	Min	Typ	Max	Unit
Static Characteristics						
BV _{DSS}	Drain-Source Breakdown Voltage	V _{GS} =0 V, I _{DS} =250 μA	100	-	-	V
V _{GS(th)}	Gate Threshold Voltage	V _{DS} =V _{GS} , I _{DS} =250 μA	2	-	4	V
I _{DSS}	Drain Leakage Current	V _{DS} =80 V, V _{GS} =0 V	-	-	1	μA
I _{GSS}	Gate Leakage Current	V _{DS} =0 V, V _{GS} =±20 V	-	-	±100	nA
R _{DS(ON)} ^a	On-State Resistance	V _{GS} =10 V, I _{DS} =80 A	-	1.05	1.25	mΩ
		V _{GS} =6 V, I _{DS} =80 A	-	1.55	1.85	mΩ
Diode Characteristics						
V _{SD} ^a	Diode Forward Voltage	V _{GS} =0 V, I _{SD} =30 A	-	-	1.3	V
t _{rr}	Reverse Recovery Time	V _{GS} =0 V, I _{DS} =30A, dI _{SD} /dt=100 A/μs	-	121	-	ns
Q _{rr}	Reverse Recovery Charge		-	405	-	nC
Dynamic Characteristics^b						
C _{iss}	Input Capacitance	V _{DS} =50 V, V _{GS} =0 V, Frequency=1 MHz	-	13766	-	pF
C _{oss}	Output Capacitance		-	2155	-	
C _{rss}	Reverse Transfer Capacitance		-	100	-	
t _{d(on)}	Turn-on Delay Time	V _{DS} =50 V, V _{GEN} =10 V, R _G =3.9 Ω, R _L =1.66 Ω, I _{DS} =30 A	-	36	-	ns
t _r	Turn-on Rise Time		-	85	-	
t _{d(off)}	Turn-off Delay Time		-	182	-	
t _f	Turn-off Fall Time		-	113	-	
Gate Charge Characteristics^b						
Q _g	Total Gate Charge	V _{DS} =50 V, V _{GS} =10 V, I _{DS} =30 A	-	284	-	nC
Q _{gs}	Gate-Source Charge		-	73	-	
Q _{gd}	Gate-Drain Charge		-	85	-	

Notes:

- Pulse test; pulse width ≤ 300 μs, duty cycle ≤ 2%.
- Guaranteed by design, not subject to production testing.

7. Typical Characteristics

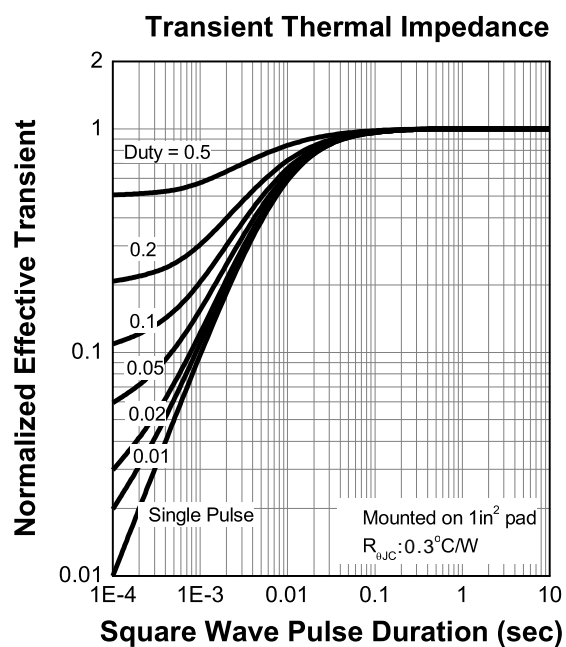
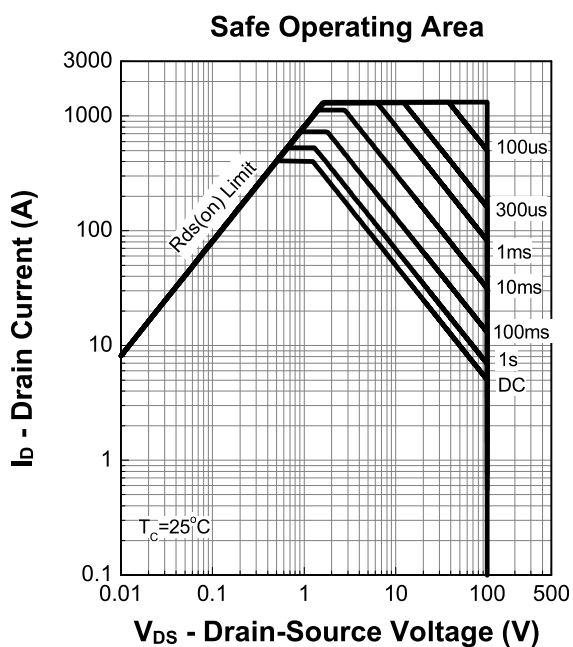
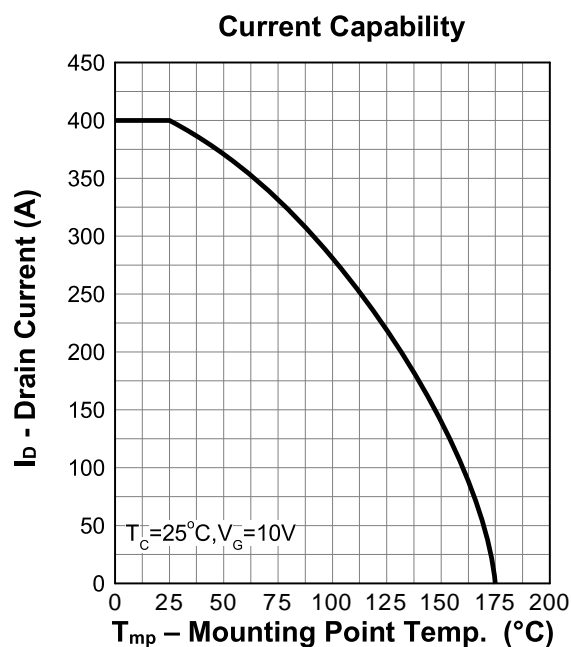
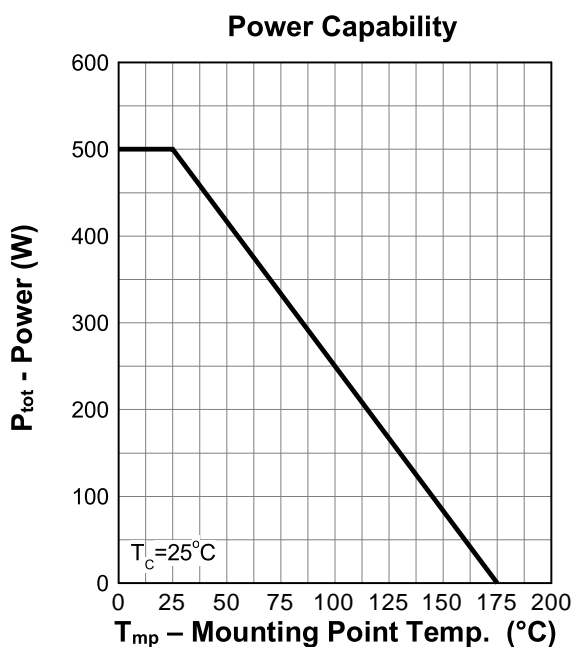

7. Typical Characteristics (cont.)

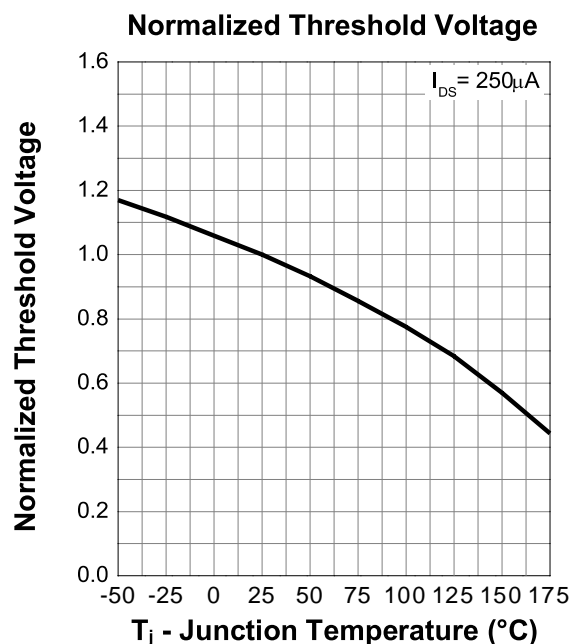
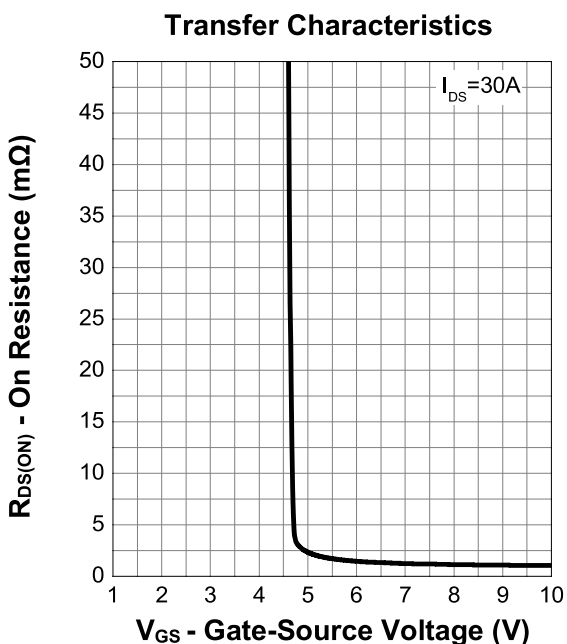
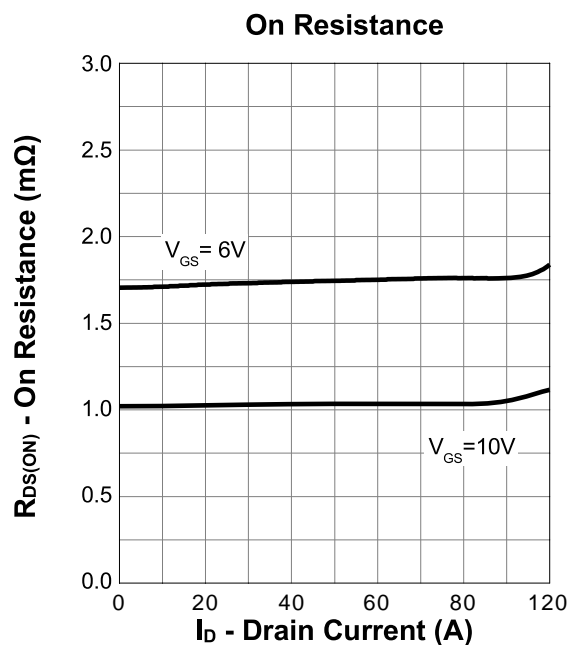
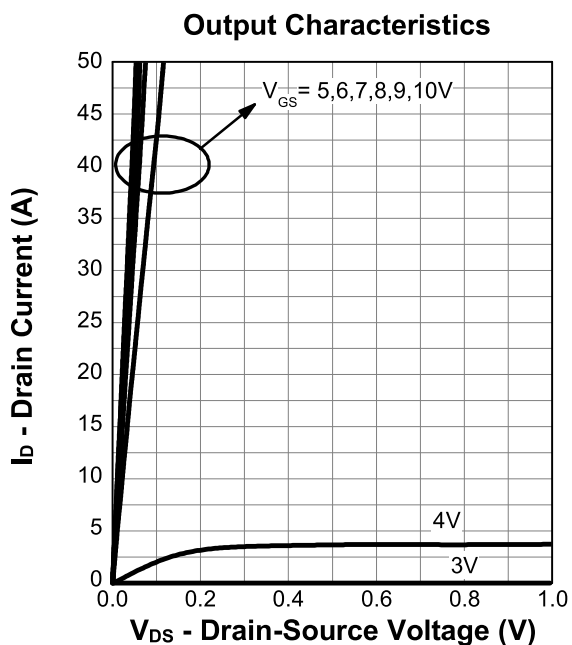

7. Typical Characteristics (cont.)

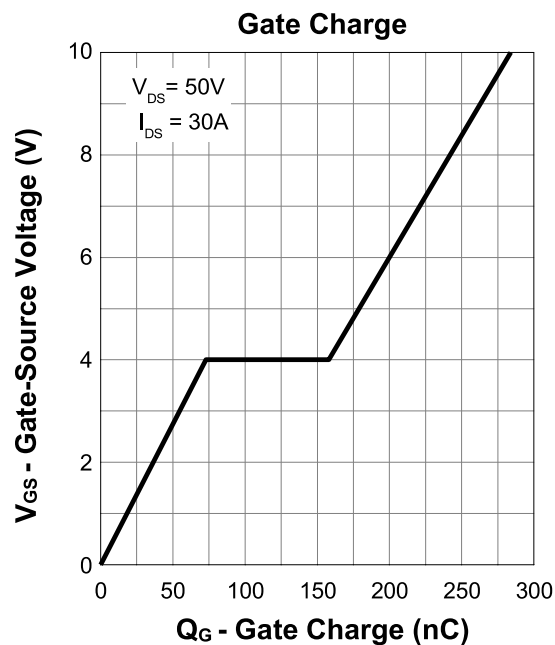
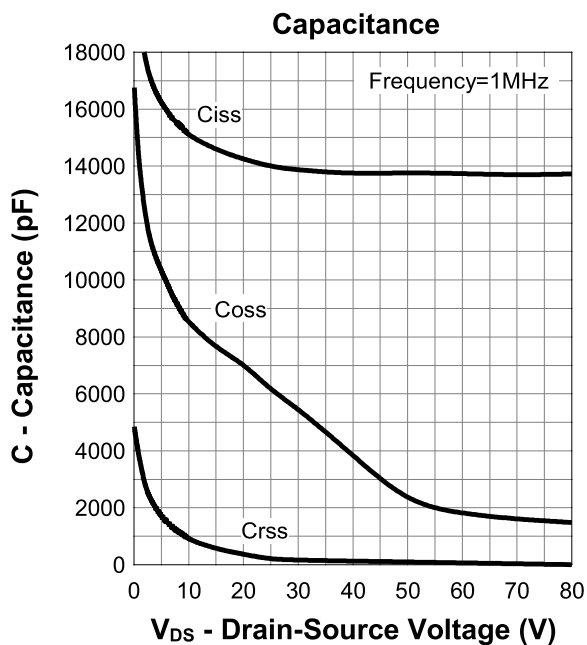
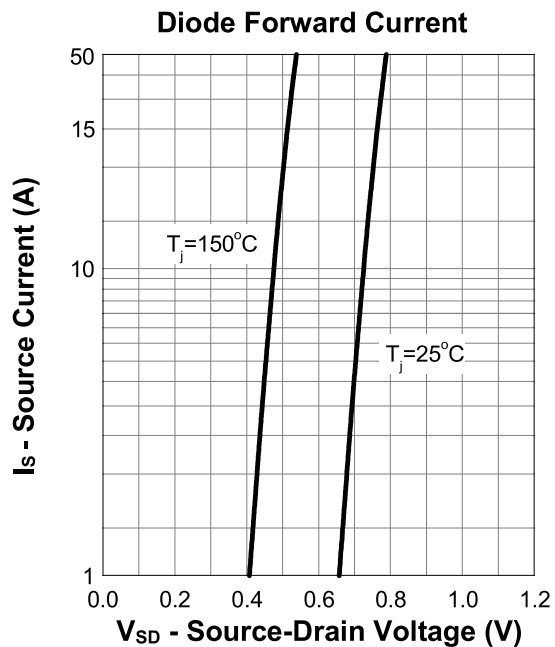
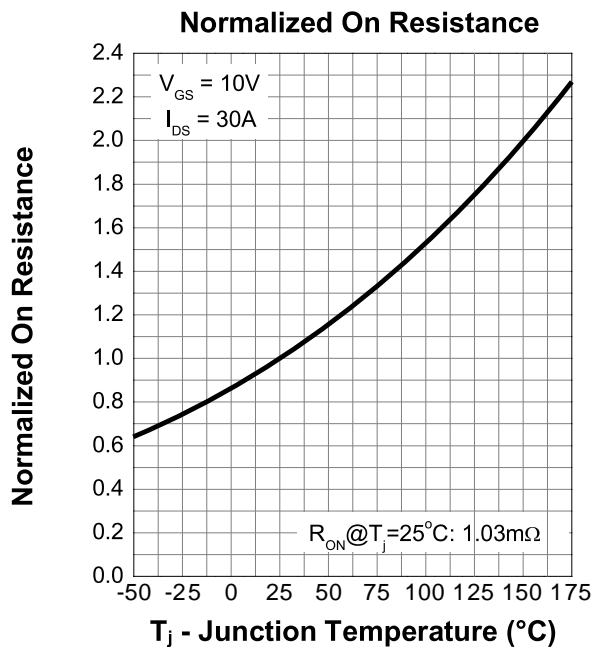

8. Package Dimensions

TOLL-8L Package

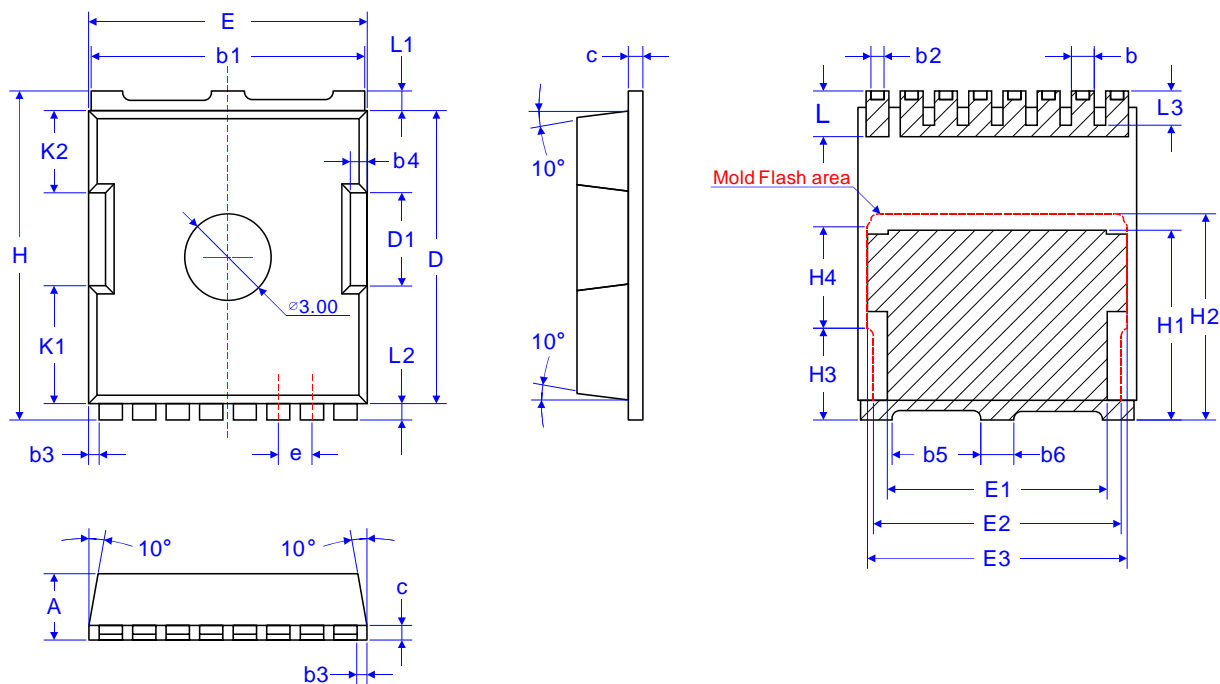

Symbol	Dimensions in Millimeters		
	MIN	NOM	MAX
A	2.20	2.30	2.40
b	0.70	0.80	0.90
b1	9.70	9.80	9.90
b2	0.42	0.46	0.50
b3		0.35	
b4		0.60	
b5		3.10	
b6		1.20	
c	0.492	0.500	0.508
D	10.28	10.38	10.48
D1		3.30	
E	9.80	9.90	10.00
E1		7.80	
E2		8.80	

Symbol	Dimensions in Millimeters		
	MIN	NOM	MAX
E3		9.20	
e		1.20 BSC	
H	11.58	11.68	11.78
H1	6.65	6.75	6.85
H2		7.30	
H3		3.20	
H4		3.80	
K1		4.18	
K2		2.90	
L	1.70	1.90	2.10
L1		0.70	
L2		0.60	
L3	1.05	1.15	1.25