

N-Channel Enhancement Mode MOSFET

1. Product Information

1.1 Features

- Advanced trench cell design
- Low thermal resistance
- T_J 175°C
- MSL1

1.2 Applications

- Motor drivers
- DC/DC converter

1.3 Quick reference

- BV ≥ 200 V
- R_{DS(ON)} ≤ 9.0 mΩ @V_{GS} = 10 V
- P_D ≤ 410 W
- I_D ≤ 138 A

2. Pin Description

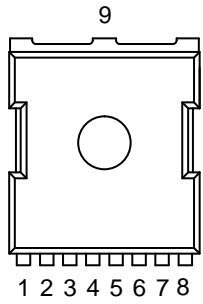
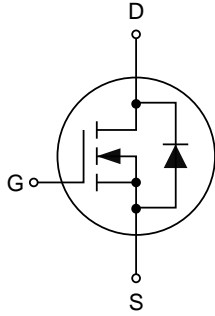
Pin	Description	Simplified Outline	Symbol
1	Gate	 <p style="text-align: center;">Top View TOLL-8L</p>	
2,3,4,5,6,7,8	Source		
9	Drain		

3. Limiting Values

Symbol	Parameter	Conditions	Min	Max	Unit
V_{DS}	Drain-Source Voltage	$T_C=25^{\circ}C$	-	200	V
V_{GS}	Gate-Source Voltage	$T_C=25^{\circ}C$	-	± 20	V
I_D^*	Drain Current (DC)	$T_C=25^{\circ}C, V_{GS}=10\text{ V}$	-	138	A
		$T_C=100^{\circ}C, V_{GS}=10\text{ V}$	-	94	A
$I_{DM}^{*,**}$	Drain Current (Pulsed)	$T_C=25^{\circ}C, V_{GS}=10\text{ V}$	-	480	A
P_D^*	Drain Power Dissipation	$T_C=25^{\circ}C$	-	410	W
I_S	Diode Forward Current	$T_C=25^{\circ}C$	-	138	A
E_{AS}^*	Single Pulsed Avalanche Energy	$V_{DD}=100\text{ V}, L=0.5\text{ mH}$	-	1829	mJ
T_J, T_{stg}	Operating Junction and Storage Temperature Range		-55	175	$^{\circ}C$
$R_{\theta JA}^*$	Thermal Resistance-Junction to Ambient		-	55	$^{\circ}C/W$
$R_{\theta JC}^*$	Thermal Resistance-Junction to Case		-	0.36	$^{\circ}C/W$

Notes:

- * Surface Mounted on 1 in² pad area, $t \leq 10$ sec.
- ** Pulse width $\leq 300\ \mu s$, duty cycle $\leq 2\%$.
- *** Limited by bonding wire.

4. Marking Information

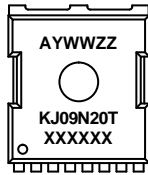
Product Name	Marking
KJ09N20T	

5. Ordering Code

Product Name	Package	Reel size	Tape width	Quantity (pcs)
KJ09N20T	TOLL-8L	13"	24 mm	2000

Note: KUIJIEXIN defines "Green" as lead-free (RoHS compliant) and halogen free (Br or Cl does not exceed 900 ppm by weight in homogeneous material and total of Br and Cl does not exceed 1500 ppm by weight; Follow IEC 61249-2-21 and IPC/JEDEC J-STD-020C).

6. Electrical Characteristics (T_A=25°C unless otherwise noted)

Symbol	Parameter	Conditions	Min	Typ	Max	Unit
Static Characteristics						
BV _{DSS}	Drain-Source Breakdown Voltage	V _{GS} =0 V, I _{DS} =250 μA	200	-	-	V
V _{GS(th)}	Gate Threshold Voltage	V _{DS} =V _{GS} , I _{DS} =250 μA	2	-	4	V
I _{DSS}	Drain Leakage Current	V _{DS} =160 V, V _{GS} =0 V	-	-	1	μA
I _{GSS}	Gate Leakage Current	V _{DS} =0 V, V _{GS} =±20 V	-	-	±100	nA
R _{DS(ON)} ^a	On-State Resistance	V _{GS} =10 V, I _{DS} =20 A	-	7.5	9.0	mΩ
R _G	Gate Resistance	V _{GS} =V _{DS} =0 V, f=1 MHz	-	4.7	-	Ω
g _{FS}	Forward Transconductance	V _{DS} =5 V, I _D =20 A	-	58	-	S
Diode Characteristics						
V _{SD} ^a	Diode Forward Voltage	I _{SD} =1 A, V _{GS} =0 V	-	-	1.0	V
t _{rr}	Reverse Recovery Time	I _{SD} =20 A, V _{GS} =0 V dI _{SD} /dt=100 A/μs	-	182	-	ns
Q _{rr}	Reverse Recovery Charge		-	739	-	nC
Dynamic Characteristics^b						
C _{iss}	Input Capacitance	V _{GS} =0 V, V _{DS} =100 V, f=1 MHz	-	8768	-	pF
C _{oss}	Output Capacitance		-	450	-	
C _{rss}	Reverse Transfer Capacitance		-	18	-	
t _{d(on)}	Turn-on Delay Time	V _{DS} =100 V, V _{GEN} =10 V, R _G =3 Ω, R _L =5 Ω, I _{DS} =20 A	-	30	-	ns
t _r	Turn-on Rise Time		-	58	-	
t _{d(off)}	Turn-off Delay Time		-	97	-	
t _f	Turn-off Fall Time		-	44	-	
Gate Charge Characteristics^b						
Q _g	Total Gate Charge	V _{DS} =100 V, V _{GS} =10 V, I _{DS} =20 A	-	120	-	nC
Q _{gs}	Gate-Source Charge		-	41	-	
Q _{gd}	Gate-Drain Charge		-	21	-	

Notes:

- Pulse test; pulse width ≤ 300 μs, duty cycle ≤ 2%.
- Guaranteed by design, not subject to production testing.

7. Typical Characteristics

Power Capability

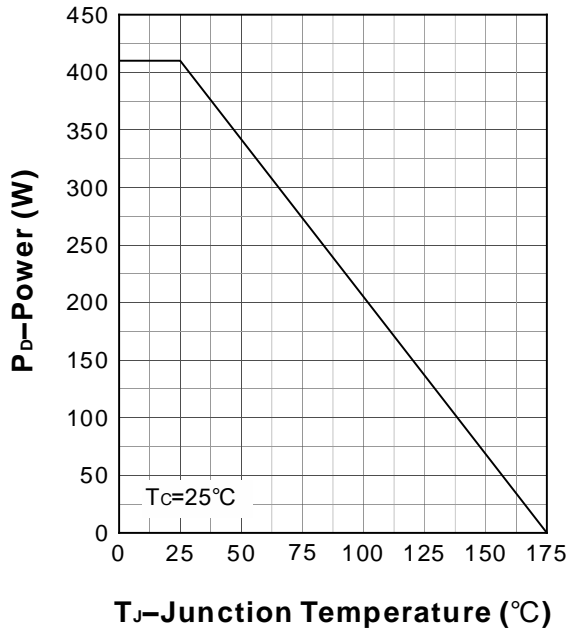

Current Capability

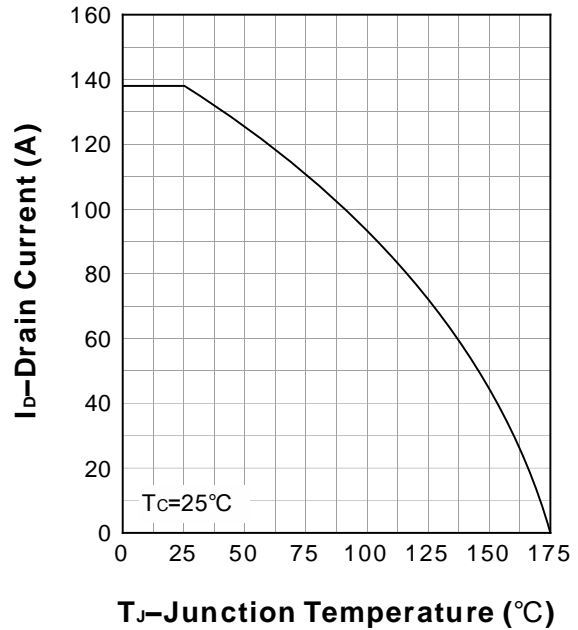

Safe Operating Area

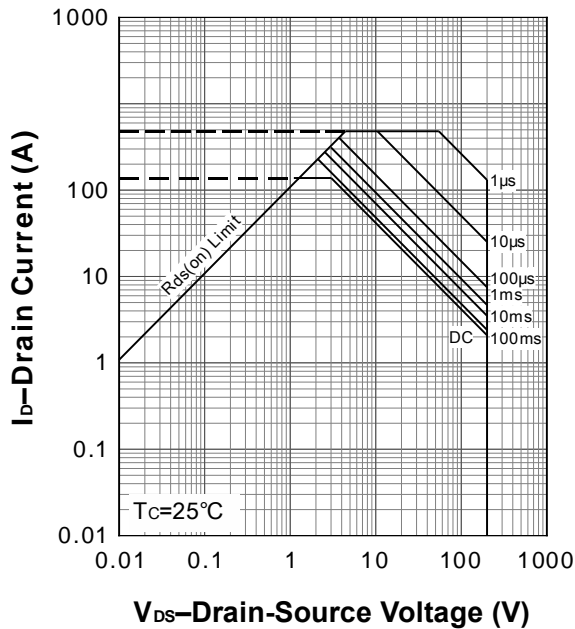

Transient Thermal Impedance

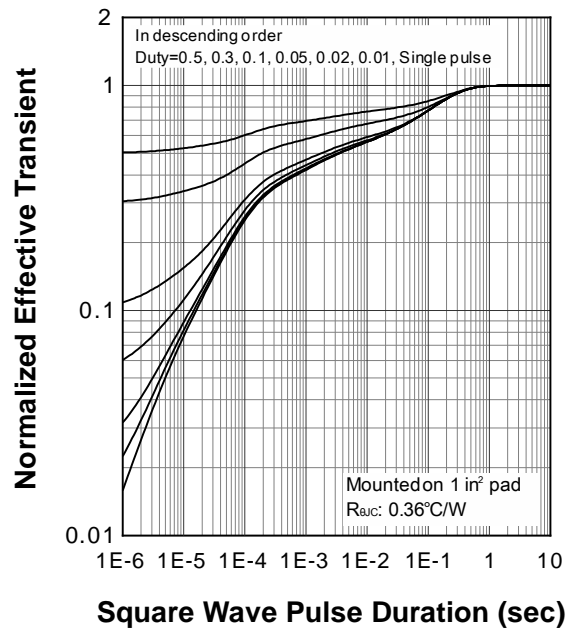

7. Typical Characteristics (cont.)

Output Characteristics

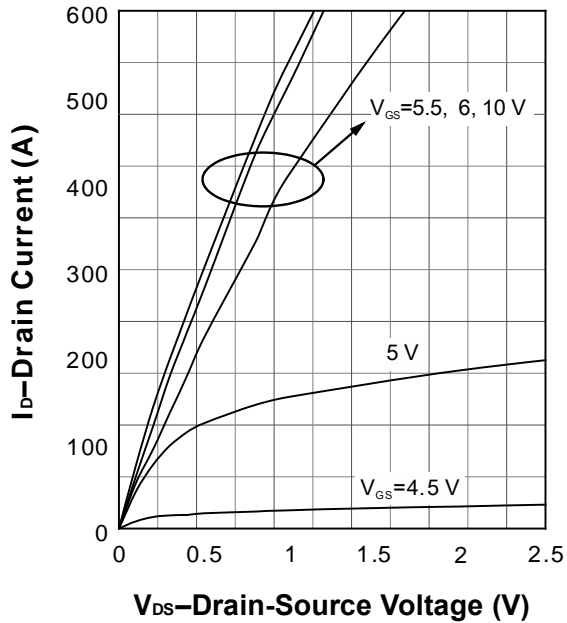

On Resistance

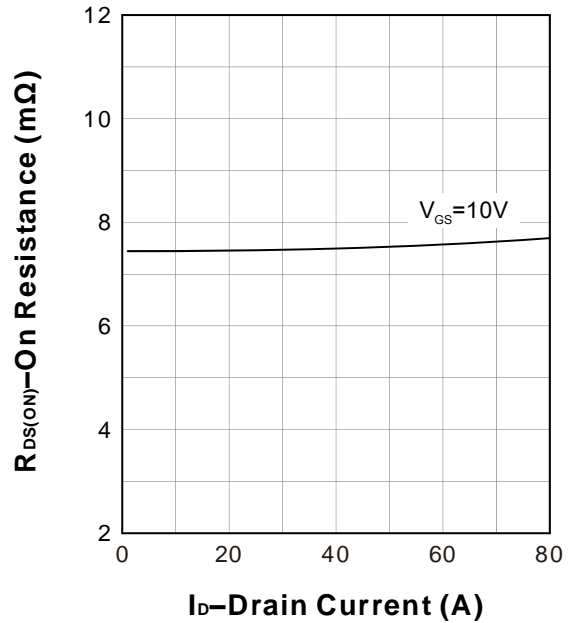

Transfer Characteristics

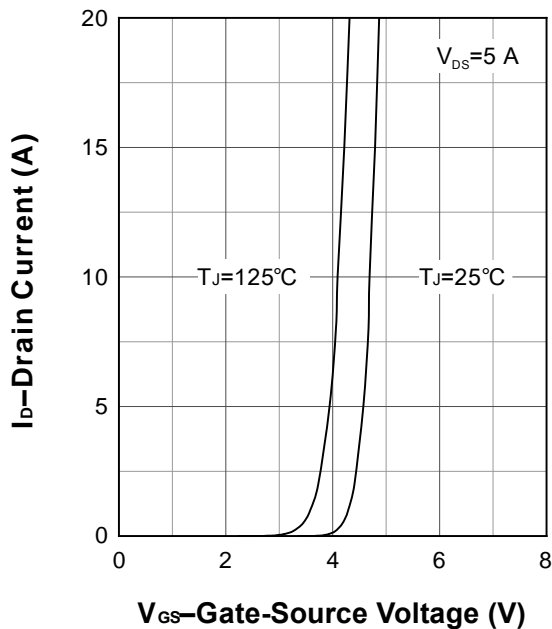

Normalized Threshold Voltage

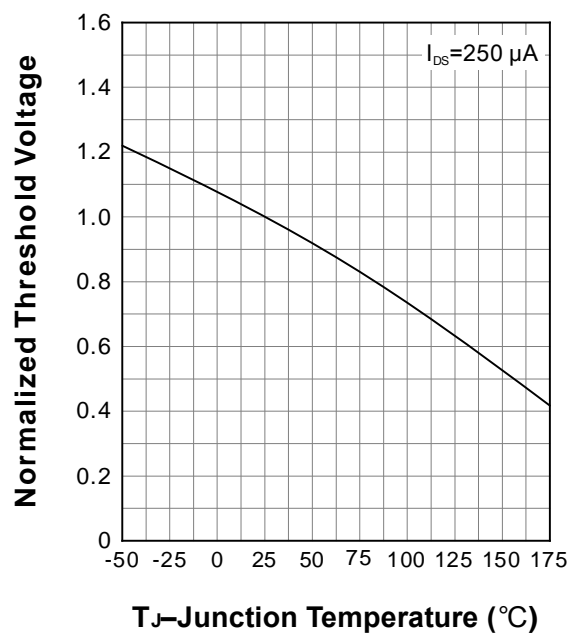

7. Typical Characteristics (cont.)

Normalized On Resistance

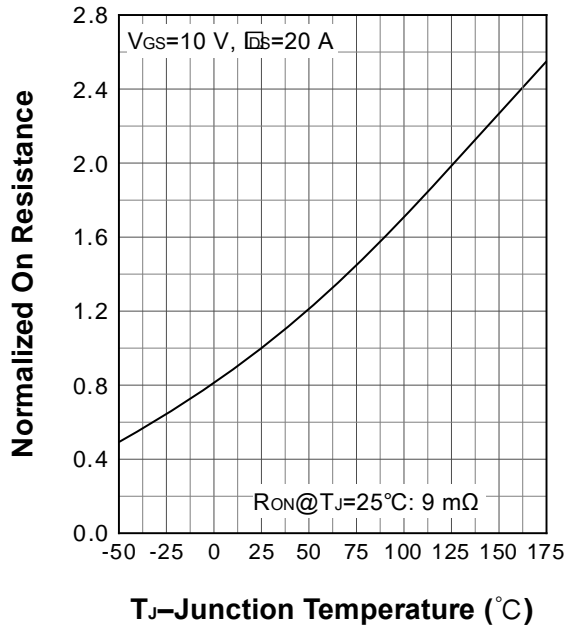

Diode Forward Current

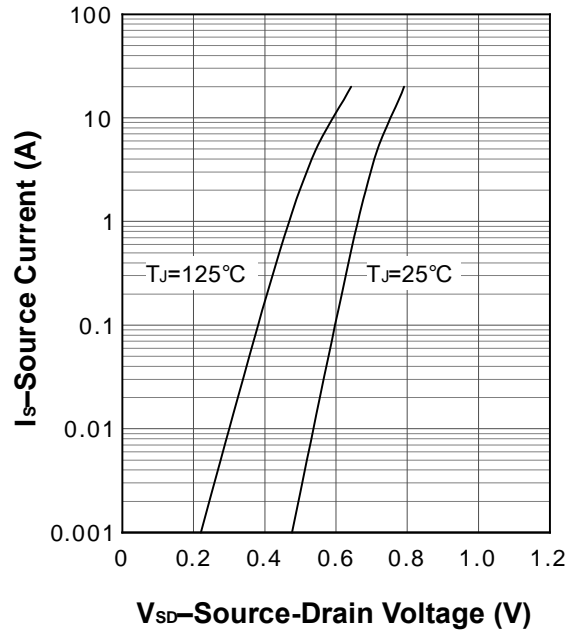

Capacitance

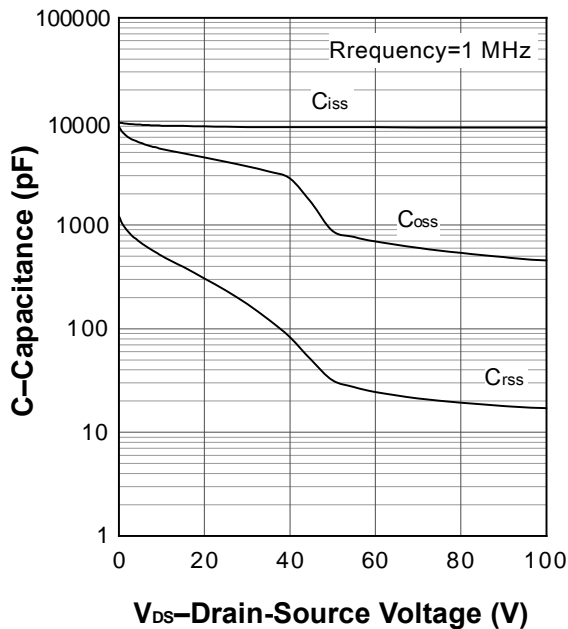

Gate Charge

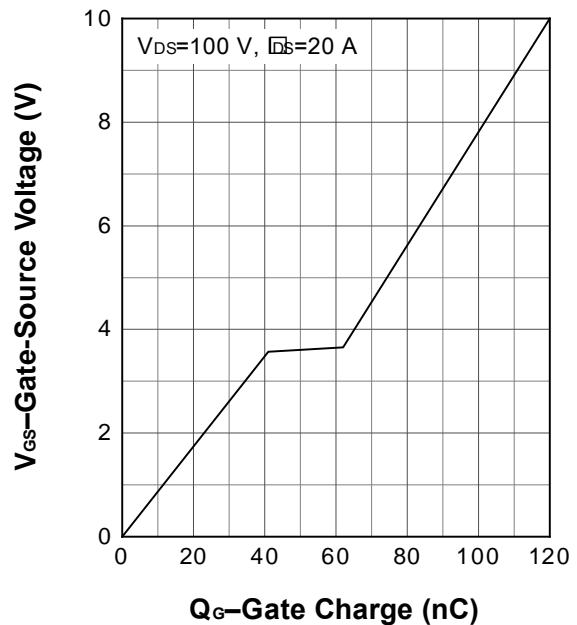

8. Package Dimensions

TOLL-8L Package

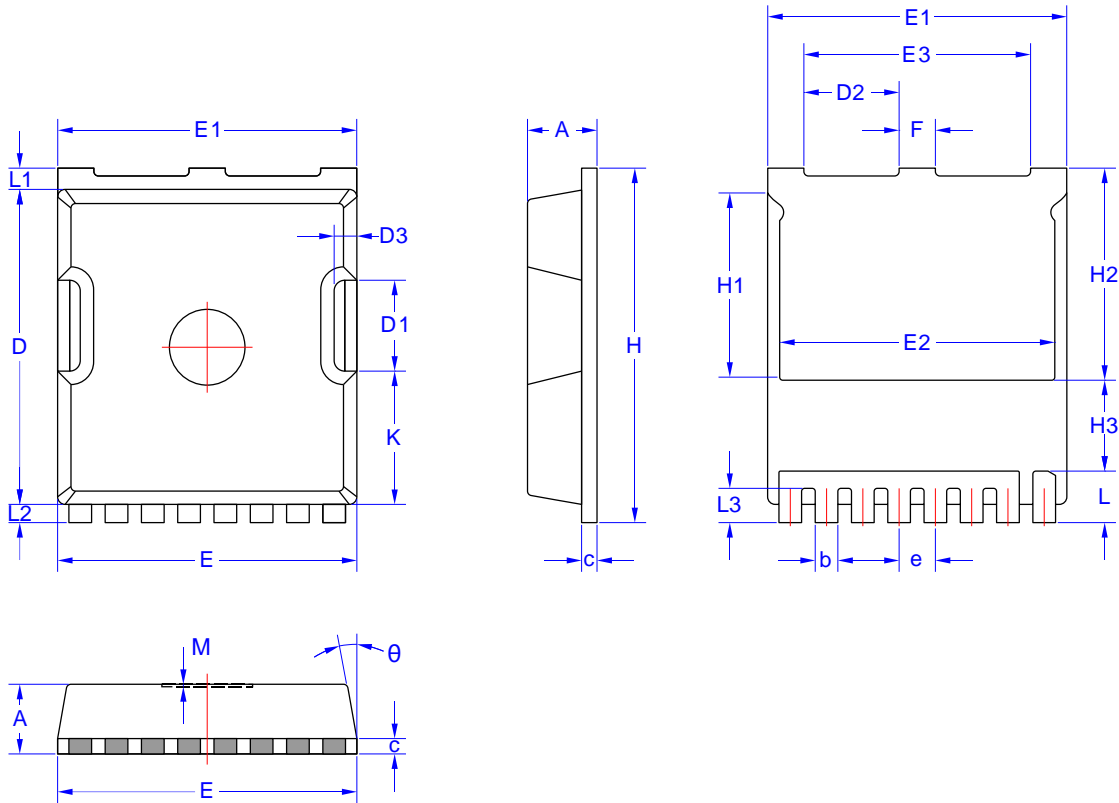

Symbol	Dimensions in Millimeters		
	MIN	NOM	MAX
A	2.20	2.30	2.40
b	0.65	0.75	0.85
c		0.508 REF	
D	10.25	10.40	10.55
D1	2.85	3.00	3.15
D2	2.95	3.10	3.25
D3		0.75 REF	
E	9.75	9.90	10.05
E1	9.65	9.80	9.95
E2	8.95	9.10	9.25
E3	7.25	7.40	7.55
e		1.20 BSC	

Symbol	Dimensions in Millimeters		
	MIN	NOM	MAX
F	1.05	1.20	1.35
H	11.55	11.70	11.85
H1	6.03	6.18	6.33
H2	6.85	7.00	7.15
H3		3.00 BSC	
K	4.25	4.40	4.55
L	1.55	1.70	1.85
L1	0.55	0.70	0.85
L2	0.45	0.60	0.75
L3	1.00	1.15	1.30
M		0.08 REF	
θ	8°	10°	12°