

## N-Channel Enhancement Mode MOSFET

### 1. Product Information

#### Features

- VD-MOSFET technology
- Improve switching performance

#### Applications

- Uninterruptible Power Supply (UPS)
- Power Factor Correction (PFC)

#### Quick reference

- $V_{DS} = 200\text{ V}$
- $I_D = 28\text{ A}$
- $R_{DS(ON)} \leq 100\text{ m}\Omega @ V_{GS} = 10\text{ V}$  (Type:80 m $\Omega$ )

#### Pin Description

Pin	Description
1	Gate(G)
2	Drain(D)
3	Source(S)

#### Simplified Outline

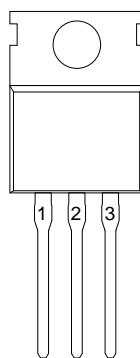

Top View  
TO-220

#### Symbol

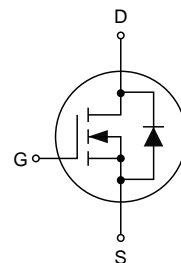

#### Package Marking and Ordering Information

Product Name	Package	Marking	Reel size	Tape width	Quantity (pcs)
KJ28N20C	TO-220	<b>KJ28N20C</b> <b>XXXXYY</b>	N/A	N/A	1000

### 2. Absolute Maximum Ratings (T<sub>C</sub>=25°C unless otherwise noted)

Symbol	Parameter	Values	Unit
$V_{DS}$	Drain-Source Voltage, $V_{GS}=0V$	200	V
$V_{GS}$	Gate-Source Voltage	$\pm 20$	V
$I_D$	Continuous Drain Current	28	A
$I_{DM}$	Pulsed Drain Current <sup>1</sup>	84	A
$E_{AS}$	Single Pulse Avalanche Energy <sup>2</sup>	340	mJ
$P_D$	Power Dissipation @T <sub>C</sub> =25°C	104	W
T <sub>J</sub> , T <sub>STG</sub>	Operating Junction and Storage Temperature Range	-55~150	°C
R <sub>θJA</sub>	Thermal Resistance, Junction to Ambient	62.5	°C/W
R <sub>θJC</sub>	Thermal Resistance Junction to Case	1.2	°C/W

## 3. Electrical Characteristics (T<sub>J</sub>=25°C, unless otherwise noted)

Symbol	Parameter	Test Conditions	Min.	Typ.	Max.	Unit
BV <sub>DSS</sub>	Drain-Source Breakdown Voltage	V <sub>GS</sub> =0 V, I <sub>D</sub> =250 μA	200	220	-	V
I <sub>GSS</sub>	Gate-body Leakage current	V <sub>DS</sub> =0 V, V <sub>GS</sub> =±20 V	-	-	±100	nA
I <sub>DSS</sub>	Zero Gate Voltage Drain Current	V <sub>DS</sub> =200 V, V <sub>GS</sub> =0 V, T <sub>J</sub> =25°C	-	-	5	μA
		V <sub>DS</sub> =160 V, V <sub>GS</sub> =0 V, T <sub>J</sub> =125°C	-	-	100	
V <sub>GS(th)</sub>	Gate-Threshold Voltage	V <sub>DS</sub> =V <sub>GS</sub> , I <sub>D</sub> =250 μA	2	3	4	V
R <sub>DS(on)</sub>	Drain-Source on-Resistance <sup>3</sup>	V <sub>GS</sub> =10 V, I <sub>D</sub> =9 A	-	80	100	mΩ
C <sub>iss</sub>	Input Capacitance	V <sub>GS</sub> =0 V, V <sub>DS</sub> =25 V, f=1 MHz	-	1511	-	pF
C <sub>oss</sub>	Output Capacitance		-	192	-	
C <sub>rss</sub>	Reverse Transfer Capacitance		-	81	-	
Q <sub>g</sub>	Total Gate Charge	V <sub>DS</sub> =160 V, V <sub>GS</sub> =10 V, I <sub>D</sub> =18 A	-	43	-	nC
Q <sub>gs</sub>	Gate-Source Charge		-	6	-	
Q <sub>gd</sub>	Gate-Drain Charge		-	20	-	
t <sub>d(on)</sub>	Turn-on Delay Time	V <sub>DD</sub> =100 V, R <sub>G</sub> =25 Ω, I <sub>D</sub> =18 A	-	24	-	ns
t <sub>r</sub>	Turn-on Rise Time		-	46	-	
t <sub>d(off)</sub>	Turn-off Delay Time		-	108	-	
t <sub>f</sub>	Turn-off Fall Time		-	94	-	
I <sub>S</sub>	Continuous Source Current	T <sub>C</sub> =25°C	-	-	28	A
I <sub>SM</sub>	Pulsed Diode Forward Current		-	-	84	A
V <sub>SD</sub>	Diode Forward Voltage	T <sub>J</sub> =25°C, I <sub>SD</sub> =18 A, V <sub>GS</sub> =0 V	-	-	1.4	V
t <sub>rr</sub>	Body Diode Reverse Recovery Time	V <sub>GS</sub> =0 V, I <sub>S</sub> =18 A, diF/dt=100 A/μs	-	233	-	ns
Q <sub>rr</sub>	Body Diode Reverse Recovery Charge		-	1.9	-	μC

Notes:

1. The data tested by surface mounted on a 1 inch<sup>2</sup> FR-4 board with 2 OZ copper.
2. The EAS data shows Max. rating. I<sub>AS</sub>=20 A, V<sub>DD</sub>=50 V, R<sub>G</sub>=25 Ω, Starting T<sub>J</sub>=25°C.
3. The test condition is Pulse Test: Pulse width ≤ 300 μs, Duty Cycle ≤ 1%.
4. The power dissipation is limited by 150°C junction temperature.
5. The data is theoretically the same as I<sub>D</sub> and I<sub>DM</sub>, in real applications, should be limited by total power dissipation.

## 4. Typical Characteristics

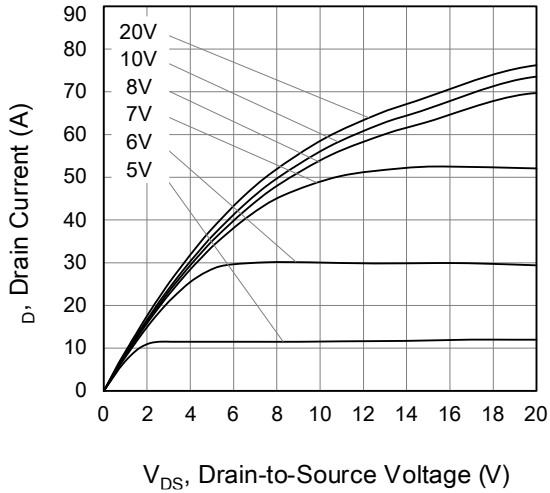

Figure 1: Output Characteristics ( $T_J=25^\circ\text{C}$ )

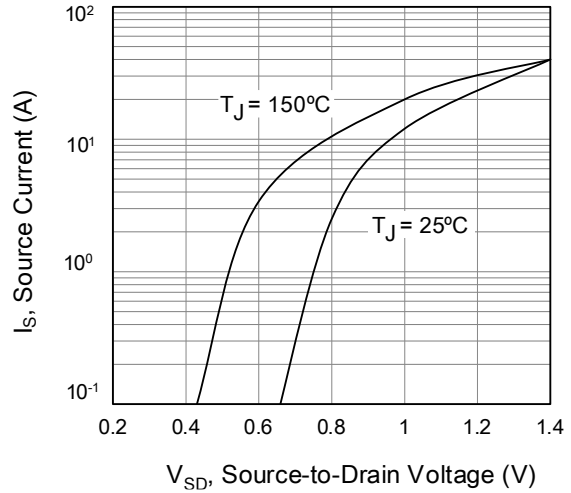

Figure 2: Body Diode Forward Voltage

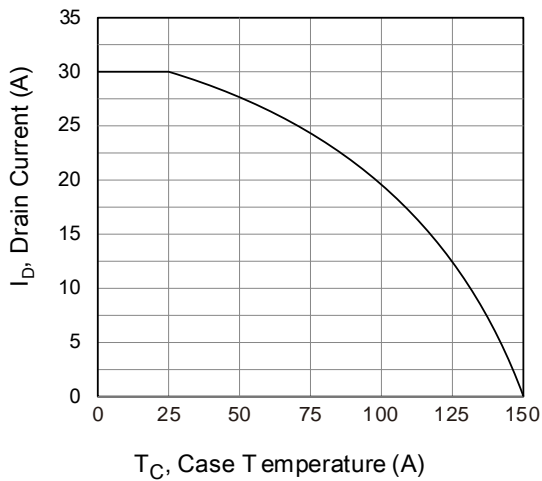

Figure 3: Drain Current vs. Temperature

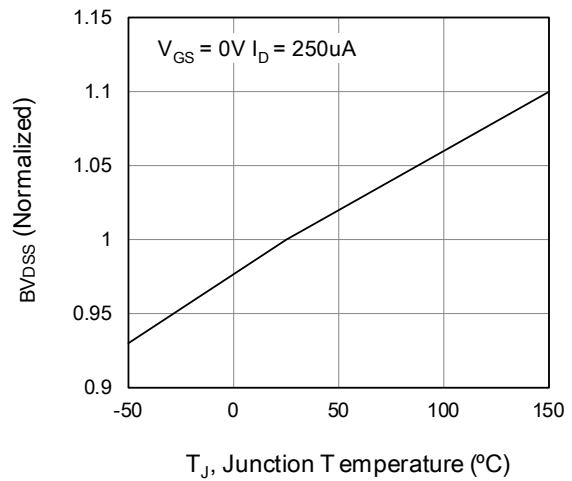

Figure 4: Body Diode Characteristics

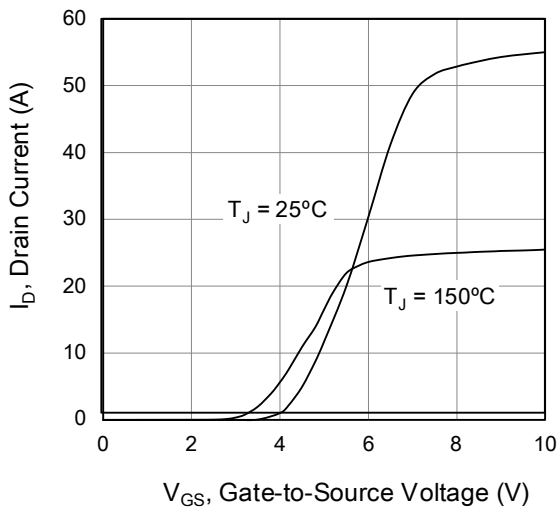

Figure 5: Transfer Characteristics

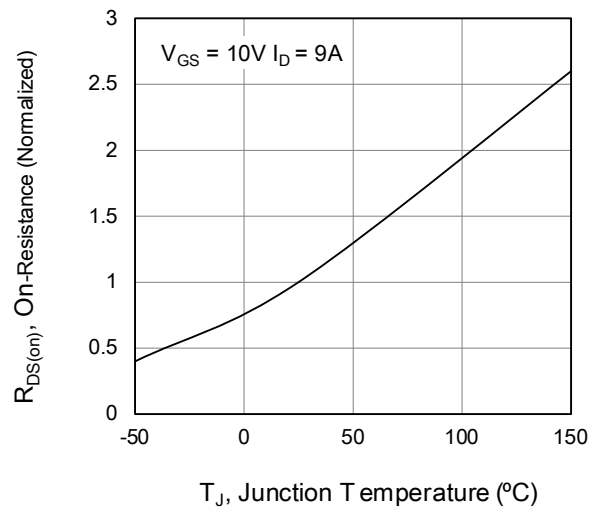
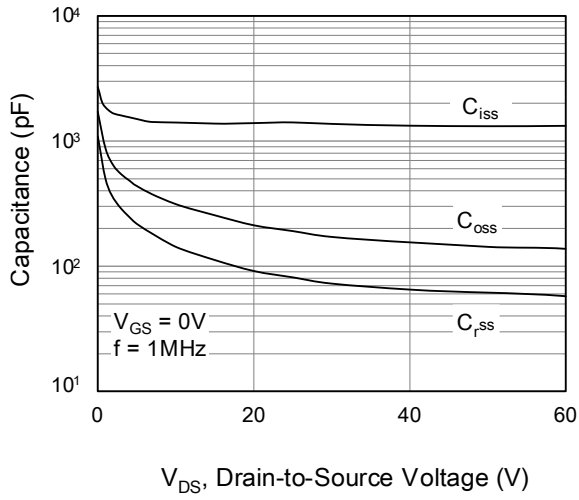
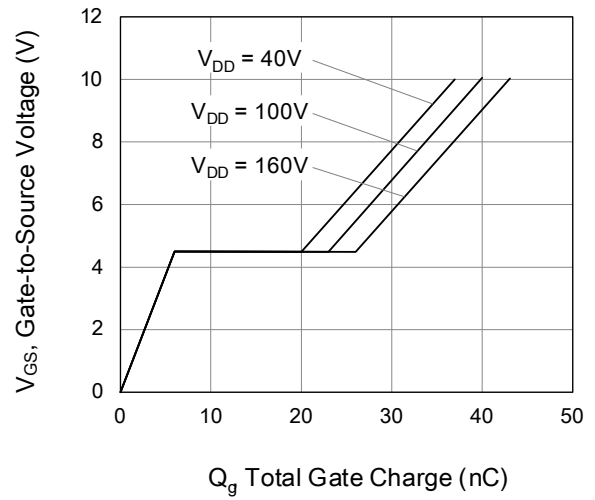

Figure 6: On-resistance vs. Temperature

## 4. Typical Characteristics (cont.)



**Figure 7: Capacitance**



**Figure 8: Gate Charge**

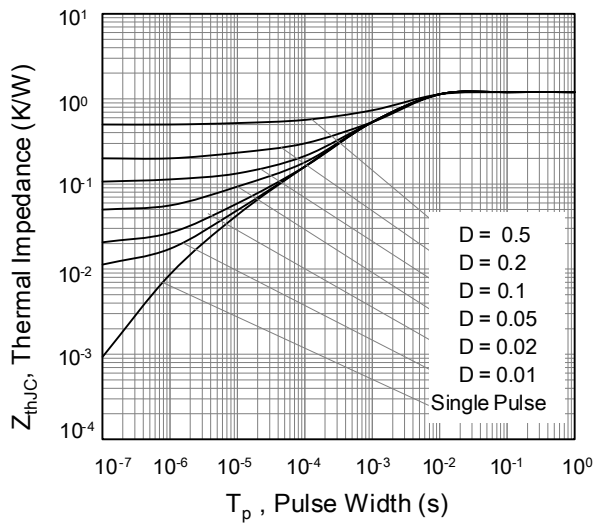

**Figure 9: Transient Thermal Impedance**

## 5. Package Mechanical Data

TO-220 Package

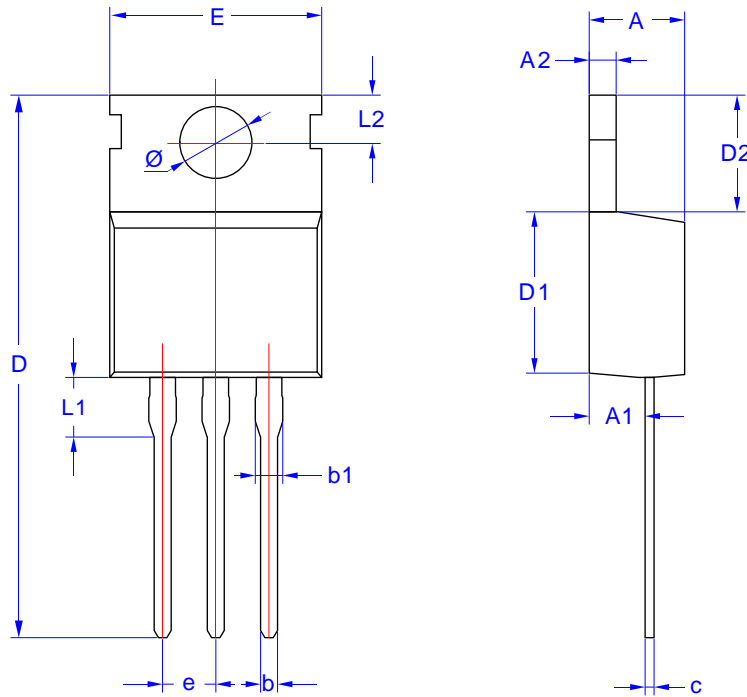

Symbol	Dimensions in Millimeters	
	MIN	MAX
A	4.24	4.70
A1	2.20	3.00
A2	1.15	1.40
b	0.70	0.95
b1	1.14	1.70
c	0.40	0.60
D	28.0	29.8
D1	8.80	9.90
D2	6.25	6.90
E	9.70	10.50
L1	3.80	
L2	2.40	3.00
e	2.54 BSC	
$\Phi$	3.60	